

The background of the cover features a large, stylized, metallic 'X' shape. The 'X' is composed of several parallel, slightly offset lines that create a sense of depth and movement. The lines are rendered in shades of gray, with a bright, glowing highlight along the central diagonal of the 'X', giving it a three-dimensional, brushed-metal appearance. The overall aesthetic is modern and technical.

**ASRock®**

# *B450M Pro4*

User Manual

Version 1.1

Published October 2020

Copyright©2020 ASRock INC. All rights reserved.

### Copyright Notice:

No part of this documentation may be reproduced, transcribed, transmitted, or translated in any language, in any form or by any means, except duplication of documentation by the purchaser for backup purpose, without written consent of ASRock Inc.

Products and corporate names appearing in this documentation may or may not be registered trademarks or copyrights of their respective companies, and are used only for identification or explanation and to the owners' benefit, without intent to infringe.

### Disclaimer:

Specifications and information contained in this documentation are furnished for informational use only and subject to change without notice, and should not be constructed as a commitment by ASRock. ASRock assumes no responsibility for any errors or omissions that may appear in this documentation.

With respect to the contents of this documentation, ASRock does not provide warranty of any kind, either expressed or implied, including but not limited to the implied warranties or conditions of merchantability or fitness for a particular purpose.

In no event shall ASRock, its directors, officers, employees, or agents be liable for any indirect, special, incidental, or consequential damages (including damages for loss of profits, loss of business, loss of data, interruption of business and the like), even if ASRock has been advised of the possibility of such damages arising from any defect or error in the documentation or product.



This device complies with Part 15 of the FCC Rules. Operation is subject to the following two conditions:

- (1) this device may not cause harmful interference, and
- (2) this device must accept any interference received, including interference that may cause undesired operation.

### CALIFORNIA, USA ONLY

The Lithium battery adopted on this motherboard contains Perchlorate, a toxic substance controlled in Perchlorate Best Management Practices (BMP) regulations passed by the California Legislature. When you discard the Lithium battery in California, USA, please follow the related regulations in advance.

“Perchlorate Material-special handling may apply, see [www.dtsc.ca.gov/hazardouswaste/perchlorate](http://www.dtsc.ca.gov/hazardouswaste/perchlorate)”

**ASRock Website: <http://www.asrock.com>**

## AUSTRALIA ONLY

Our goods come with guarantees that cannot be excluded under the Australian Consumer Law. You are entitled to a replacement or refund for a major failure and compensation for any other reasonably foreseeable loss or damage caused by our goods. You are also entitled to have the goods repaired or replaced if the goods fail to be of acceptable quality and the failure does not amount to a major failure. If you require assistance please call ASRock Tel : +886-2-28965588 ext.123 (Standard International call charges apply)

The terms HDMI® and HDMI High-Definition Multimedia Interface, and the HDMI logo are trademarks or registered trademarks of HDMI Licensing LLC in the United States and other countries.



# Contents

<b>Chapter 1 Introduction</b>	<b>1</b>
1.1 Package Contents	1
1.2 Specifications	2
1.3 Motherboard Layout	7
1.4 I/O Panel	9
<b>Chapter 2 Installation</b>	<b>10</b>
2.1 Installing the CPU	11
2.2 Installing the CPU Fan and Heatsink	13
2.3 Installing Memory Modules (DIMM)	21
2.4 Expansion Slots (PCI Express Slots)	25
2.5 Jumpers Setup	26
2.6 Onboard Headers and Connectors	27
2.7 CrossFireX™ and Quad CrossFireX™ Operation Guide	32
2.7.1 Installing Two CrossFireX™-Ready Graphics Cards	32
2.7.2 Driver Installation and Setup	34
2.8 M.2_SSD (NGFF) Module Installation Guide (M2_1)	35
2.9 M.2_SSD (NGFF) Module Installation Guide (M2_2)	38
<b>Chapter 3 Software and Utilities Operation</b>	<b>41</b>
3.1 Installing Drivers	41
3.2 A-Tuning	42
3.2.1 Installing A-Tuning	42
3.2.2 Using A-Tuning	42

3.3	ASRock Live Update & APP Shop	45
3.3.1	UI Overview	45
3.3.2	Apps	46
3.3.3	BIOS & Drivers	49
3.3.4	Setting	50
3.4	ASRock Polychrome RGB	51
<b>Chapter 4 UEFI SETUP UTILITY</b>		<b>54</b>
4.1	Introduction	54
4.1.1	UEFI Menu Bar	54
4.1.2	Navigation Keys	55
4.2	Main Screen	56
4.3	OC Tweaker Screen	57
4.4	Advanced Screen	59
4.4.1	CPU Configuration	60
4.4.2	North Bridge Configuration	61
4.4.3	South Bridge Configuration	62
4.4.4	Storage Configuration	63
4.4.5	Super IO Configuration	64
4.4.6	ACPI Configuration	65
4.4.7	Trusted Computing	66
4.4.8	AMD CBS	67
4.4.9	AMD PBS	75
4.5	Tools	76
4.6	Hardware Health Event Monitoring Screen	78

---

4.7	Security Screen	81
4.8	Boot Screen	82
4.9	Exit Screen	84

# Chapter 1 Introduction

Thank you for purchasing ASRock B450M Pro4 motherboard, a reliable motherboard produced under ASRock's consistently stringent quality control. It delivers excellent performance with robust design conforming to ASRock's commitment to quality and endurance.

In this manual, Chapter 1 and 2 contains the introduction of the motherboard and step-by-step installation guides. Chapter 3 contains the operation guide of the software and utilities. Chapter 4 contains the configuration guide of the BIOS setup.



*Because the motherboard specifications and the BIOS software might be updated, the content of this manual will be subject to change without notice. In case any modifications of this manual occur, the updated version will be available on ASRock's website without further notice. If you require technical support related to this motherboard, please visit our website for specific information about the model you are using. You may find the latest VGA cards and CPU support list on ASRock's website as well. ASRock website <http://www.asrock.com>.*

## 1.1 Package Contents

- ASRock B450M Pro4 Motherboard (Micro ATX Form Factor)
- ASRock B450M Pro4 Quick Installation Guide
- ASRock B450M Pro4 Support CD
- 1 x I/O Panel Shield
- 2 x Serial ATA (SATA) Data Cables (Optional)
- 2 x Screws for M.2 Sockets (Optional)

## 1.2 Specifications

- Platform**
- Micro ATX Form Factor
  - Solid Capacitor design

- CPU**
- AMD AM4 Socket
  - Digi Power design
  - 9 Power Phase design

- Chipset**
- AMD Promontory B450

- Memory**
- Dual Channel DDR4 Memory Technology
  - 4 x DDR4 DIMM Slots
  - AMD Ryzen series CPUs (Matisse) support DDR4 3200/2933/2667/2400/2133 ECC & non-ECC, un-buffered memory\*
  - AMD Ryzen series CPUs (Pinnacle Ridge) support DDR4 3200+(OC)/2933(OC)/2667/2400/2133 ECC & non-ECC, un-buffered memory\*
  - AMD Ryzen series CPUs (Picasso) support DDR4 2933/2667/2400/2133 non-ECC, un-buffered memory\*
  - AMD Ryzen series CPUs (Summit Ridge) support DDR4 3200+(OC)/2933(OC)/2667/2400/2133 ECC & non-ECC, un-buffered memory\*
  - AMD Ryzen series CPUs (Raven Ridge) support DDR4 3200+(OC)/2933/2667/2400/2133 non-ECC, un-buffered memory\*

\* For Ryzen Series CPUs (Picasso and Raven Ridge), ECC is only supported with PRO CPUs.

\* Please refer to Memory Support List on ASRock's website for more information. (<http://www.asrock.com/>)

\* Please refer to page 21 for the table for AMD non-XMP memory frequency support. For more details, please refer to the QVL on ASRock's website.

- Max. capacity of system memory: 64GB
- Supports Extreme Memory Profile (XMP) memory modules
- 15µ Gold Contact in DIMM Slots



## Expansion Slot

### AMD Ryzen series CPUs (Matisse, Summit Ridge and Pinnacle Ridge)

- 1 x PCI Express 3.0 x16 Slot (PCIe2: x16 mode)\*
- 1 x PCI Express 2.0 x16 Slot (PCIe3: x4 mode)

### AMD Ryzen series CPUs (Picasso, Raven Ridge)

- 1 x PCI Express 3.0 x16 Slot (PCIe2: x8 mode)\*
- 1 x PCI Express 2.0 x16 Slot (PCIe3: x4 mode)

### AMD Athlon series CPUs

- 1 x PCI Express 3.0 x16 Slot (PCIe2: x4 mode)\*
- 1 x PCI Express 2.0 x16 Slot (PCIe3: x4 mode)

•

\* Supports NVMe SSD as boot disks

- 1 x PCI Express 2.0 x1 Slot
- Supports AMD Quad CrossFireX™ and CrossFireX™

## Graphics

- Integrated AMD Radeon™ Vega Series Graphics in Ryzen Series APU\*

\* Actual support may vary by CPU

- DirectX 12, Pixel Shader 5.0
- Shared memory default 2GB. Max Shared memory supports up to 16GB.

\* The Max shared memory 16GB requires 32GB system memory installed.

- Three graphics output options: D-Sub, DVI-D and HDMI
- Supports Triple Monitor
- Supports HDMI 1.4 with max. resolution up to 4K x 2K (4096x2160) @ 24Hz / (3840x2160) @ 30Hz
- Supports DVI-D with max. resolution up to 1920x1200 @ 60Hz
- Supports D-Sub with max. resolution up to 1920x1200 @ 60Hz
- Supports Auto Lip Sync, Deep Color (12bpc), xvYCC and HBR (High Bit Rate Audio) with HDMI 1.4 Port (Compliant HDMI monitor is required)
- Supports HDCP 1.4 with DVI-D and HDMI 1.4 Ports
- Supports 4K Ultra HD (UHD) playback with HDMI 1.4 Port

## Audio

- 7.1 CH HD Audio with Content Protection (Realtek ALC892 Audio Codec)
- Premium Blu-ray Audio support
- Supports Surge Protection
- ELNA Audio Caps

## LAN

- PCIE x1 Gigabit LAN 10/100/1000 Mb/s
- Realtek RTL8111H
- Supports Wake-On-LAN
- Supports Lightning/ESD Protection
- Supports Energy Efficient Ethernet 802.3az
- Supports PXE

## Rear Panel I/O

- 1 x PS/2 Mouse/Keyboard Port
- 1 x D-Sub Port
- 1 x DVI-D Port
- 1 x HDMI Port
- 2 x USB 2.0 Ports (Supports ESD Protection)
- 1 x USB 3.2 Gen2 Type-A Port (10 Gb/s) (Supports ESD Protection)
- 1 x USB 3.2 Gen2 Type-C Port (10 Gb/s) (Supports ESD Protection)
- 4 x USB 3.2 Gen1 Ports (Supports ESD Protection)
- 1 x RJ-45 LAN Port with LED (ACT/LINK LED and SPEED LED)
- HD Audio Jacks: Line in / Front Speaker / Microphone

## Storage

- 4 x SATA3 6.0 Gb/s Connectors, support RAID (RAID 0, RAID 1 and RAID 10), NCQ, AHCI and Hot Plug\*  
\* M2\_2 and SATA3\_3 share lanes. If either one of them is in use, the other one will be disabled.
- 1 x Ultra M.2 Socket (M2\_1), supports M Key type 2242/2260/2280 M.2 PCI Express module up to Gen3 x4 (32 Gb/s) (with Matisse, Picasso, Summit Ridge, Raven Ridge and Pinnacle Ridge) or Gen3 x2 (16 Gb/s) (with Athlon series APU)\*\*
- \*\* Supports NVMe SSD as boot disks
- \*\* Supports ASRock U.2 Kit
- 1 x M.2 Socket (M2\_2), supports M Key type 2230/2242/2260/2280 M.2 SATA3 6.0 Gb/s module

**Connector**

- 1 x COM Port Header
- 1 x TPM Header
- 1 x Chassis Intrusion Header
- 1 x Power LED and Speaker Header
- 1 x RGB LED Header
- \* Supports in total up to 12V/3A, 36W LED Strip
  - 1 x Addressable LED Header
- \* Supports in total up to 5V/3A, 15W LED Strip
  - 1 x AMD Fan LED Header
- \* The AMD Fan LED Header supports LED strips of maximum load of 3A (36W) and length up to 2.5M.
  - 1 x CPU Fan Connector (4-pin)
- \* The CPU Fan Connector supports the CPU fan of maximum 1A (12W) fan power.
  - 1 x CPU/Water Pump Fan Connector (4-pin) (Smart Fan Speed Control)
- \* The CPU/Water Pump Fan supports the water cooler fan of maximum 2A (24W) fan power.
  - 3 x Chassis/Water Pump Fan Connectors (4-pin) (Smart Fan Speed Control)
- \* The Chassis/Water Pump Fan supports the water cooler fan of maximum 2A (24W) fan power.
- \* CPU\_FAN2/WP, CHA\_FAN1/WP, CHA\_FAN2/WP and CHA\_FAN3/WP can auto detect if 3-pin or 4-pin fan is in use.
  - 1 x 24 pin ATX Power Connector
  - 1 x 8 pin 12V Power Connector
  - 1 x Front Panel Audio Connector
  - 2 x USB 2.0 Headers (Support 4 USB 2.0 ports) (Supports ESD Protection)
  - 1 x USB 3.2 Gen1 Header (Supports 2 USB 3.2 Gen1 ports) (Supports ESD Protection)

**BIOS  
Feature**

- AMI UEFI Legal BIOS with multilingual GUI support
- Supports “Plug and Play”
- ACPI 5.1 compliance wake up events
- Supports jumperfree
- SMBIOS 2.3 support
- DRAM Voltage multi-adjustment

**Hardware Monitor**

- Temperature Sensing: CPU, CPU/Water Pump, Chassis/Water Pump Fans
- Fan Tachometer: CPU, CPU/Water Pump, Chassis/Water Pump Fans
- Quiet Fan (Auto adjust chassis fan speed by CPU temperature): CPU, CPU/Water Pump, Chassis/Water Pump Fans
- Fan Multi-Speed Control: CPU, CPU/Water Pump, Chassis/Water Pump Fans
- CASE OPEN detection
- Voltage monitoring: +12V, +5V, +3.3V, Vcore

**OS**

- Microsoft® Windows® 10 64-bit

**Certifications**

- FCC, CE
- ErP/EuP ready (ErP/EuP ready power supply is required)

\* For detailed product information, please visit our website: <http://www.asrock.com>



Please realize that there is a certain risk involved with overclocking, including adjusting the setting in the BIOS, applying Untied Overclocking Technology, or using third-party overclocking tools. Overclocking may affect your system's stability, or even cause damage to the components and devices of your system. It should be done at your own risk and expense. We are not responsible for possible damage caused by overclocking.

### 1.3 Motherboard Layout

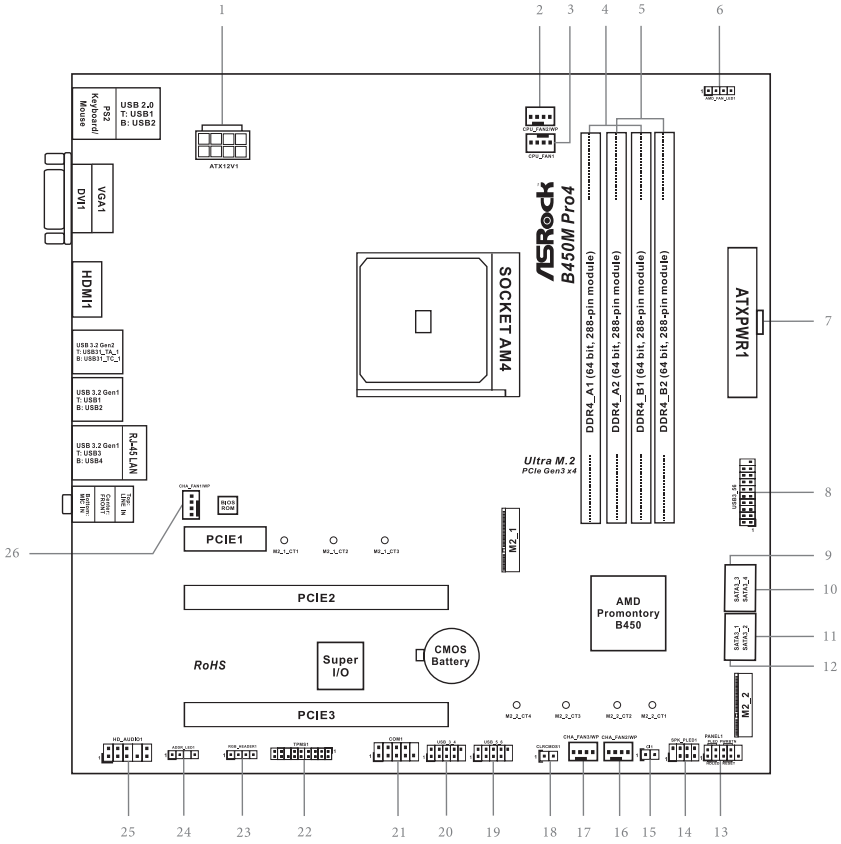

No.	Description
1	ATX 12V Power Connector (ATX12V1)
2	CPU/Water Pump Fan Connector (CPU_FAN2/WP)
3	CPU Fan Connector (CPU_FAN1)
4	2 x 288-pin DDR4 DIMM Slots (DDR4_A1, DDR4_B1)
5	2 x 288-pin DDR4 DIMM Slots (DDR4_A2, DDR4_B2)
6	AMD Fan LED Header (AMD_FAN_LED1)
7	ATX Power Connector (ATXPWR1)
8	USB 3.2 Gen1 Header (USB3_56)
9	SATA3 Connector (SATA3_3) (Upper)
10	SATA3 Connector (SATA3_4) (Lower)
11	SATA3 Connector (SATA3_2) (Lower)
12	SATA3 Connector (SATA3_1) (Upper)
13	System Panel Header (PANEL1)
14	Power LED and Speaker Header (SPK_PLED1)
15	Chassis Intrusion Header (CI1)
16	Chassis/Water Pump Fan Connector (CHA_FAN2/WP)
17	Chassis/Water Pump Fan Connector (CHA_FAN3/WP)
18	Clear CMOS Jumper (CLRCMOS1)
19	USB 2.0 Header (USB_5_6)
20	USB 2.0 Header (USB_3_4)
21	COM Port Header (COM1)
22	TPM Header (TPMS1)
23	RGB LED Header (RGB_HEADER1)
24	Addressable LED Header (ADDR_LED1)
25	Front Panel Audio Header (HD_AUDIO1)
26	Chassis/Water Pump Fan Connector (CHA_FAN1/WP)

## 1.4 I/O Panel

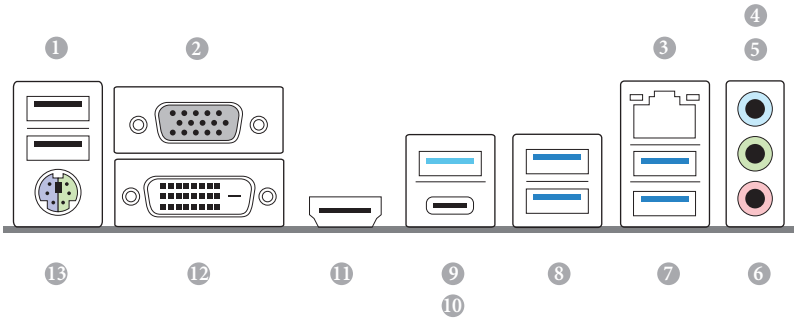

No.	Description	No.	Description
1	USB 2.0 Ports (USB_1_2)	8	USB 3.2 Gen1 Ports (USB3_12)
2	D-Sub Port	9	USB 3.2 Gen2 Type-A Port (USB31_TA_1)
3	LAN RJ-45 Port*	10	USB 3.2 Gen2 Type-C Port (USB31_TC_1)
4	Line In (Light Blue)**	11	HDMI Port
5	Front Speaker (Lime)**	12	DVI-D Port
6	Microphone (Pink)**	13	PS/2 Mouse/Keyboard Port
7	USB 3.2 Gen1 Ports (USB3_34)		

\* There are two LEDs on each LAN port. Please refer to the table below for the LAN port LED indications.

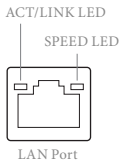

Activity / Link LED		Speed LED	
Status	Description	Status	Description
Off	No Link	Off	10Mbps connection
Blinking	Data Activity	Orange	100Mbps connection
On	Link	Green	1Gbps connection

\*\* Function of the Audio Ports in 7.1-channel Configuration:

Port	Function
Light Blue (Rear panel)	Rear Speaker Out
Lime (Rear panel)	Front Speaker Out
Pink (Rear panel)	Central /Subwoofer Speaker Out
Lime (Front panel)	Side Speaker Out

## Chapter 2 Installation

This is a Micro ATX form factor motherboard. Before you install the motherboard, study the configuration of your chassis to ensure that the motherboard fits into it.

### Pre-installation Precautions

Take note of the following precautions before you install motherboard components or change any motherboard settings.

- Make sure to unplug the power cord before installing or removing the motherboard. Failure to do so may cause physical injuries to you and damages to motherboard components.
- In order to avoid damage from static electricity to the motherboard's components, NEVER place your motherboard directly on a carpet. Also remember to use a grounded wrist strap or touch a safety grounded object before you handle the components.
- Hold components by the edges and do not touch the ICs.
- Whenever you uninstall any components, place them on a grounded anti-static pad or in the bag that comes with the components.
- When placing screws to secure the motherboard to the chassis, please do not over-tighten the screws! Doing so may damage the motherboard.



## 2.1 Installing the CPU



*Unplug all power cables before installing the CPU.*

1

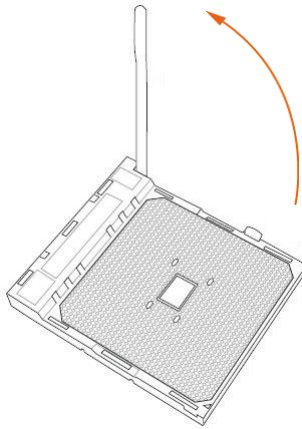

2

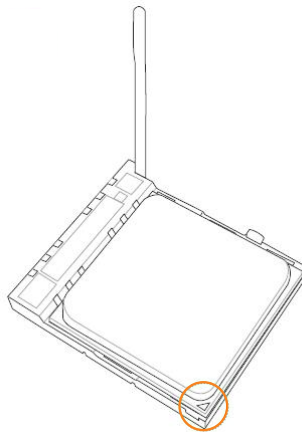

3

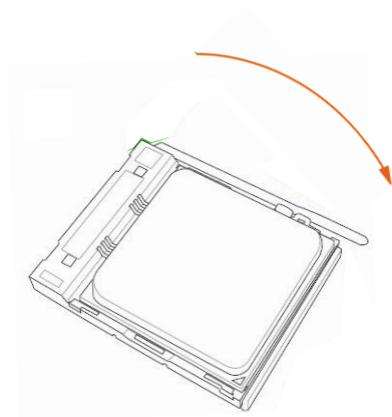

## 2.2 Installing the CPU Fan and Heatsink

After you install the CPU into this motherboard, it is necessary to install a larger heatsink and cooling fan to dissipate heat. You also need to spray thermal grease between the CPU and the heatsink to improve heat dissipation. Make sure that the CPU and the heatsink are securely fastened and in good contact with each other.



*Please turn off the power or remove the power cord before changing a CPU or heatsink.*

### Installing the CPU Box Cooler SR1

1

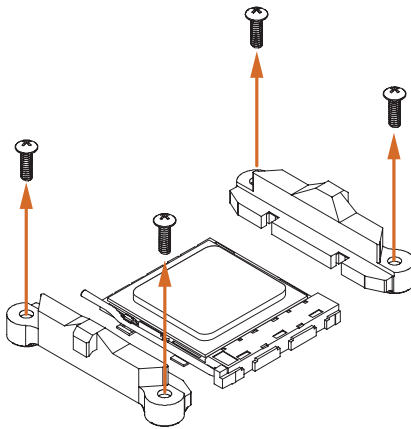

2

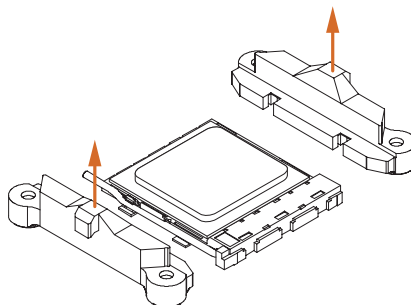

3

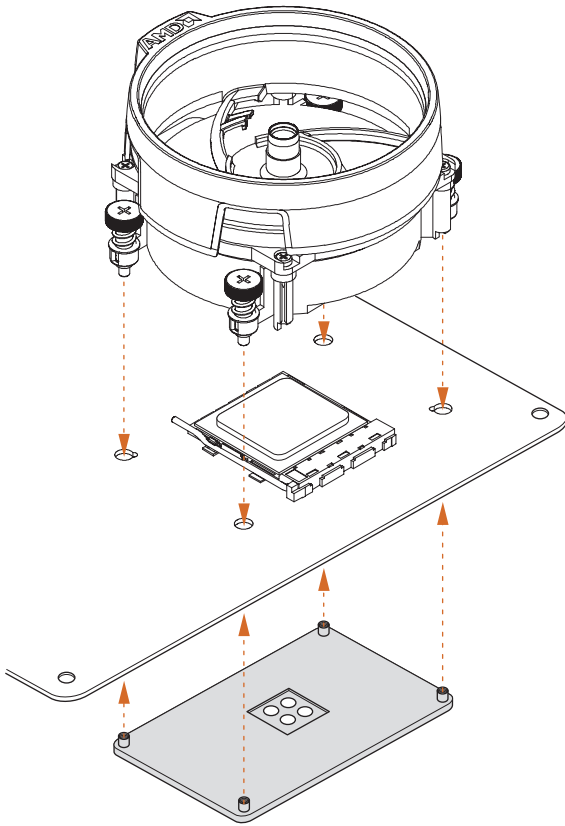

4

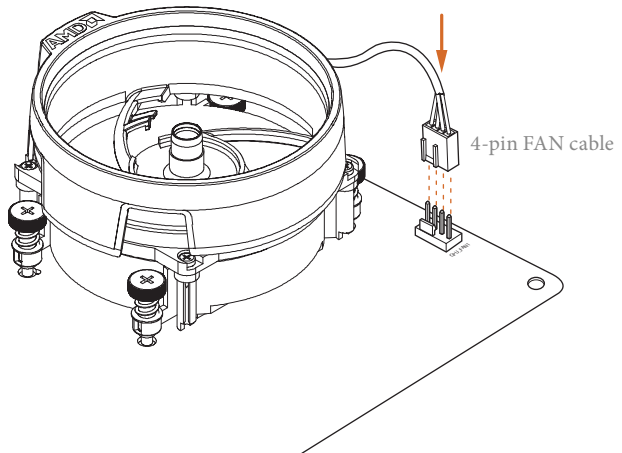

## Installing the AM4 Box Cooler SR2

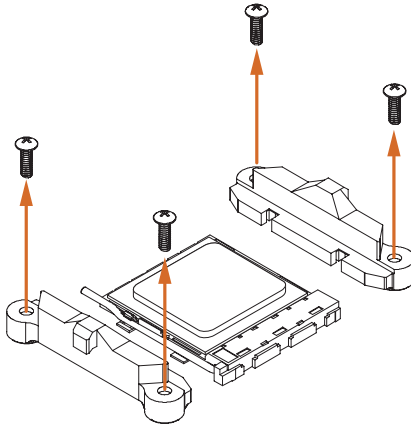
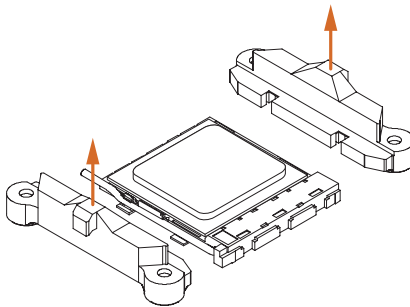
**1****2**

3

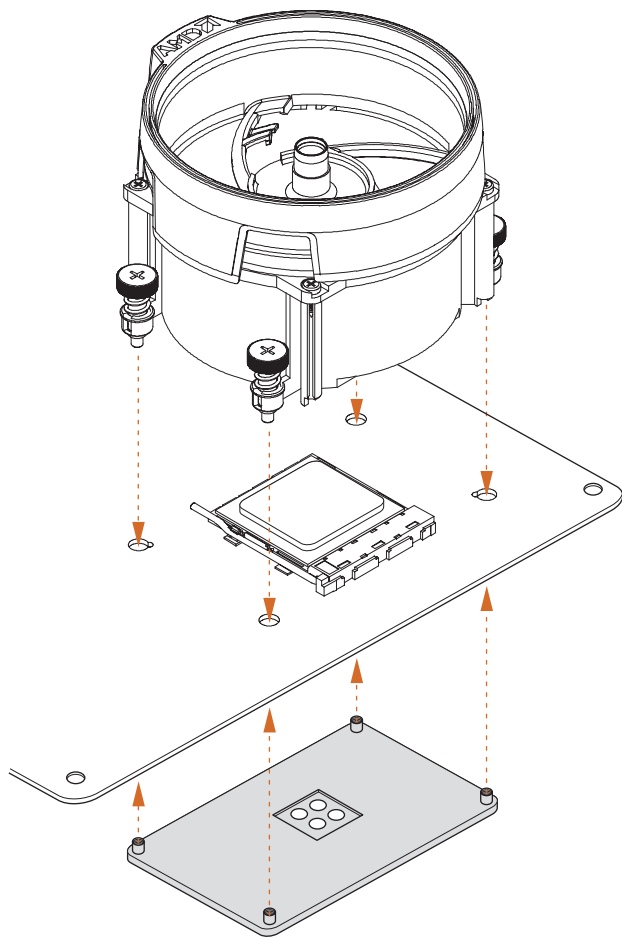

4

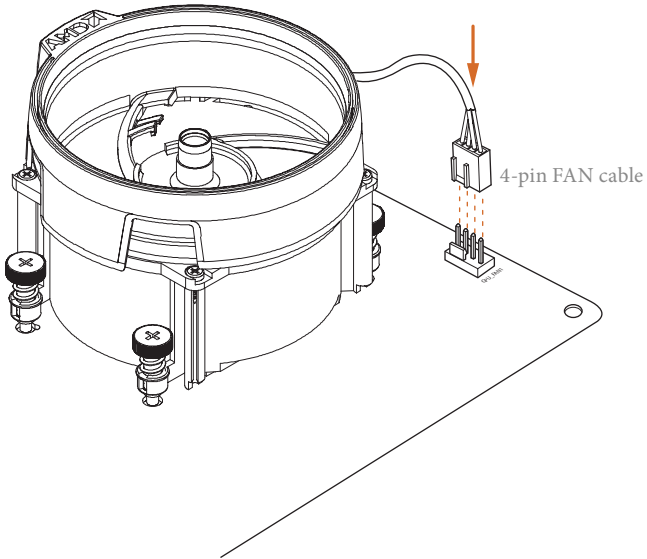

5

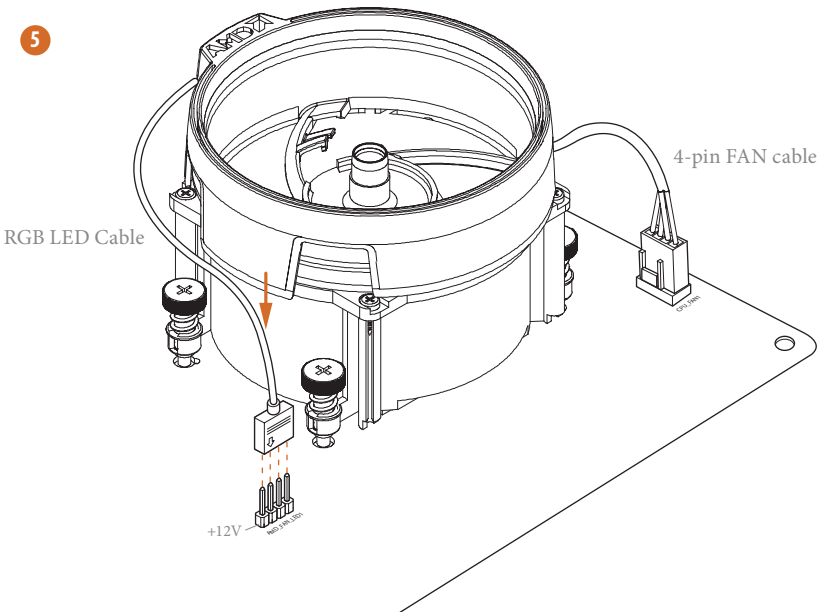

\*The diagram shown here are for reference only. Please refer to page 31 for the orientation of AMD Fan LED Header (AMD\_FAN\_LED1).

## Installing the AM4 Box Cooler SR3

1

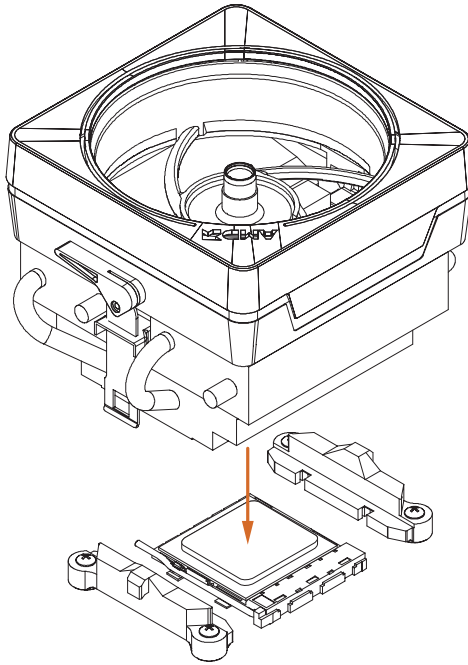

2

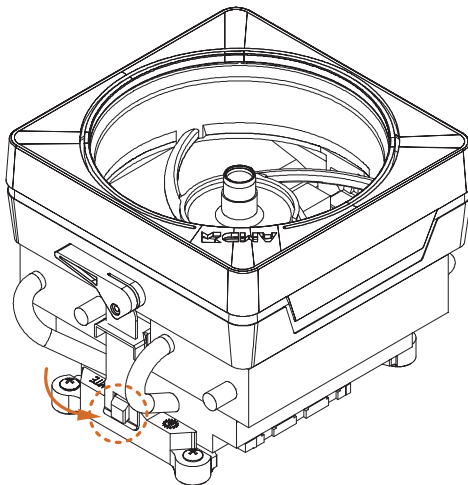



3

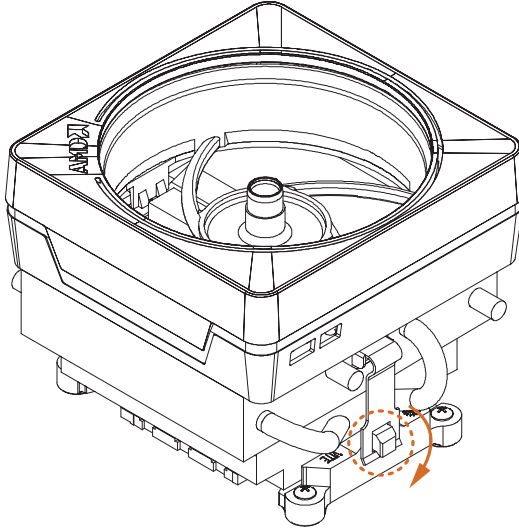

4

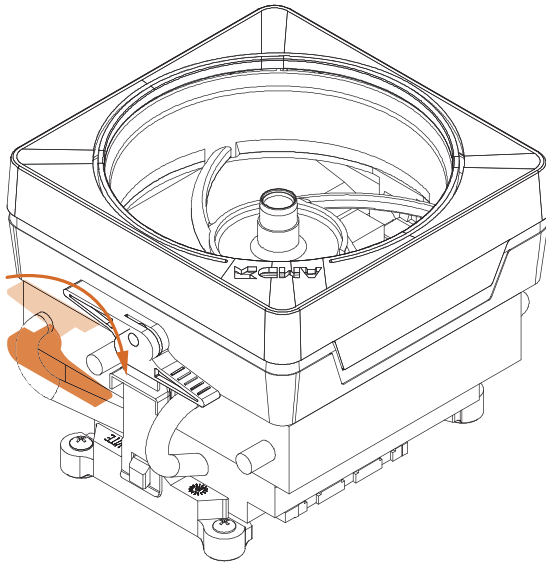

5

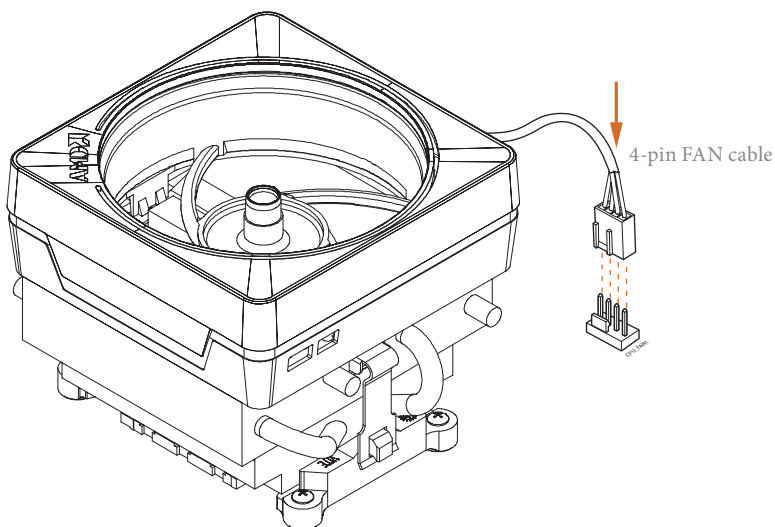

6

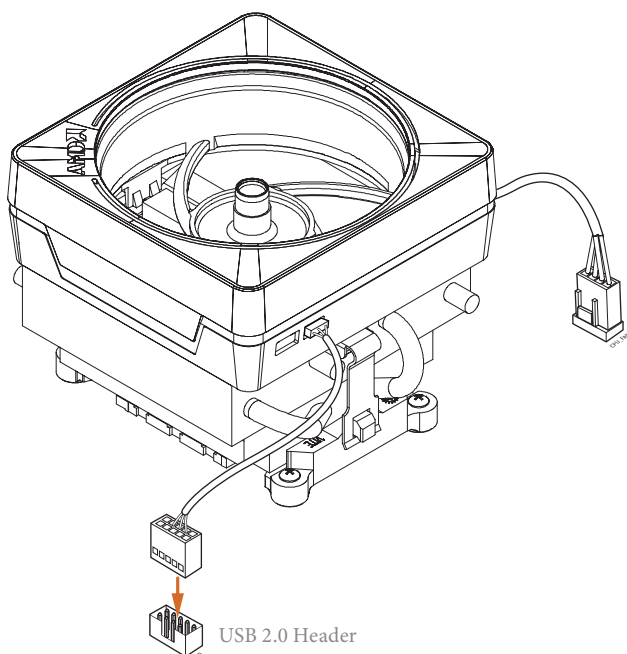

Please note that this connector is the interface to the LED control board on the SR3, it requires the AMD utility "SR3 Settings Software" to control the LED.

\*The diagram shown here are for reference only. Please refer to page 28 for the orientation of USB Header.

## 2.3 Installing Memory Modules (DIMM)

This motherboard provides four 288-pin DDR4 (Double Data Rate 4) DIMM slots, and supports Dual Channel Memory Technology.



1. For dual channel configuration, you always need to install identical (the same brand, speed, size and chip-type) DDR4 DIMM pairs.
2. It is unable to activate Dual Channel Memory Technology with only one or three memory module installed.
3. It is not allowed to install a DDR, DDR2 or DDR3 memory module into a DDR4 slot; otherwise, this motherboard and DIMM may be damaged.

### AMD non-XMP Memory Frequency Support

Ryzen Series CPUs (Matisse):

UDIMM Memory Slot				Frequency (Mhz)
A1	A2	B1	B2	
-	SR	-	-	3200
-	DR	-	-	3200
-	SR	-	SR	3200
-	DR	-	DR	3200
SR	SR	SR	SR	2933
SR/DR	DR	SR/DR	DR	2667
SR/DR	SR/DR	SR/DR	SR/DR	2667

Ryzen Series CPUs (Pinnacle Ridge):

UDIMM Memory Slot				Frequency
A1	A2	B1	B2	(Mhz)
-	SR	-	-	2933
-	DR	-	-	2933
-	SR	-	SR	2933
-	DR	-	DR	2933
SR	SR	SR	SR	2933
SR/DR	DR	SR/DR	DR	2667
SR/DR	SR/DR	SR/DR	SR/DR	2133-2400

Ryzen Series CPUs (Picasso):

UDIMM Memory Slot				Frequency
A1	A2	B1	B2	(Mhz)
-	SR	-	-	2933
-	DR	-	-	2667
-	SR	-	SR	2667
-	DR	-	DR	2400
SR	SR	SR	SR	2133
SR/DR	DR	SR/DR	DR	1866
SR/DR	SR/DR	SR/DR	SR/DR	1866

## Ryzen Series CPUs (Summit Ridge):

UDIMM Memory Slot				Frequency
A1	A2	B1	B2	(Mhz)
-	SR	-	-	2667
-	DR	-	-	2667
-	SR	-	SR	2667
-	DR	-	DR	2667
SR	SR	SR	SR	2667
SR/DR	DR	SR/DR	DR	2667
SR/DR	SR/DR	SR/DR	SR/DR	2133-2400

## Ryzen Series CPUs (Raven Ridge):

UDIMM Memory Slot				Frequency
A1	A2	B1	B2	(Mhz)
-	SR	-	-	2933
-	DR	-	-	2667
-	SR	-	SR	2667
-	DR	-	DR	2667
SR	SR	SR	SR	2667
SR/DR	DR	SR/DR	DR	2667
SR/DR	SR/DR	SR/DR	SR/DR	2133-2400

SR: Single rank DIMM, 1Rx4 or 1Rx8 on DIMM module label

DR: Dual rank DIMM, 2Rx4 or 2Rx8 on DIMM module label



The DIMM only fits in one correct orientation. It will cause permanent damage to the motherboard and the DIMM if you force the DIMM into the slot at incorrect orientation.

1

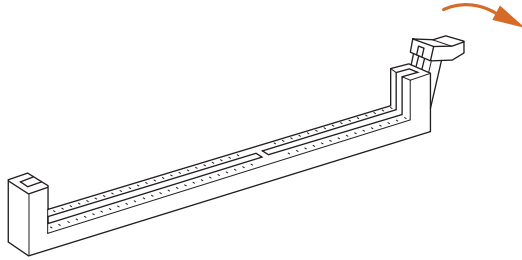

2

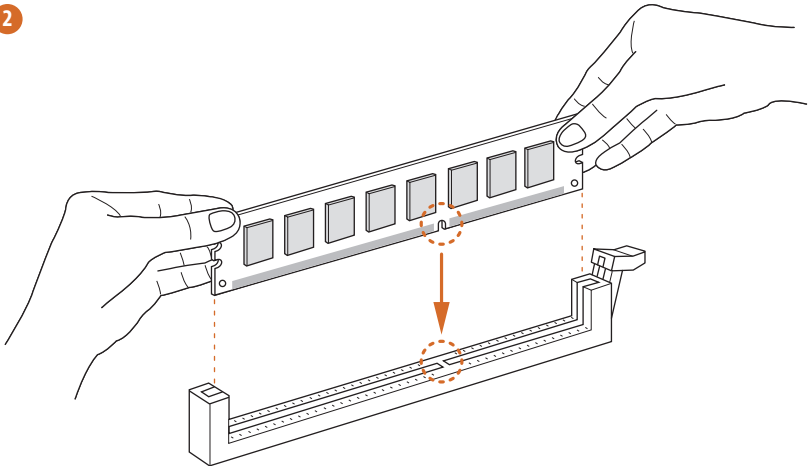

3

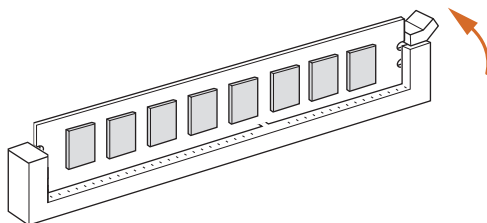

## 2.4 Expansion Slots (PCI Express Slots)

There are 3 PCI Express slots on the motherboard.



*Before installing an expansion card, please make sure that the power supply is switched off or the power cord is unplugged. Please read the documentation of the expansion card and make necessary hardware settings for the card before you start the installation.*

### PCIe slots:

PCIe1 (PCIe 2.0 x1 slot) is used for PCI Express x1 lane width cards.

PCIe2 (PCIe 3.0 x16 slot) is used for PCI Express x16 lane width graphics cards.

PCIe3 (PCIe 2.0 x16 slot) is used for PCI Express x4 lane width graphics cards.

### PCIe Slot Configurations

	PCIe1	PCIe2	PCIe3
<b>Ryzen Series CPUs (Matisse)</b>	x1	x16	x4
<b>Ryzen Series CPUs (Pinnacle Ridge)</b>	x1	x16	x4
<b>Ryzen Series CPUs (Picasso)</b>	x1	x8	x4
<b>Ryzen Series CPUs (Summit Ridge)</b>	x1	x16	x4
<b>Ryzen Series CPUs (Raven Ridge)</b>	x1	x8	x4
<b>Athlon series APU</b>	x1	x4	x4

## 2.5 Jumpers Setup

The illustration shows how jumpers are setup. When the jumper cap is placed on the pins, the jumper is “Short”. If no jumper cap is placed on the pins, the jumper is “Open”.



Short



Open

---

Clear CMOS Jumper  
(CLR CMOS1)  
(see p.7, No. 18)



2-pin Jumper

Short: Clear CMOS  
Open: Default

---

CLR CMOS1 allows you to clear the data in CMOS. To clear and reset the system parameters to default setup, please turn off the computer and unplug the power cord from the power supply. After waiting for 15 seconds, use a jumper cap to short the pins on CLR CMOS1 for 5 seconds. However, please do not clear the CMOS right after you update the BIOS. If you need to clear the CMOS when you just finish updating the BIOS, you must boot up the system first, and then shut it down before you do the clear-CMOS action. Please be noted that the password, date, time, and user default profile will be cleared only if the CMOS battery is removed. Please remember to remove the jumper cap after clearing the CMOS.



*If you clear the CMOS, the case open may be detected. Please adjust the BIOS option “Clear Status” to clear the record of previous chassis intrusion status.*



## 2.6 Onboard Headers and Connectors



Onboard headers and connectors are NOT jumpers. Do NOT place jumper caps over these headers and connectors. Placing jumper caps over the headers and connectors will cause permanent damage to the motherboard.

System Panel Header  
(9-pin PANEL1)  
(see p.7, No. 13)

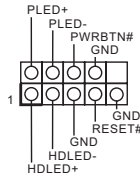

Connect the power switch, reset switch and system status indicator on the chassis to this header according to the pin assignments below. Note the positive and negative pins before connecting the cables.



**PWRBTN (Power Switch):**

Connect to the power switch on the chassis front panel. You may configure the way to turn off your system using the power switch.

**RESET (Reset Switch):**

Connect to the reset switch on the chassis front panel. Press the reset switch to restart the computer if the computer freezes and fails to perform a normal restart.

**PLED (System Power LED):**

Connect to the power status indicator on the chassis front panel. The LED is on when the system is operating. The LED keeps blinking when the system is in S3 sleep state. The LED is off when the system is in S4 sleep state or powered off (S5).

**HDLED (Hard Drive Activity LED):**

Connect to the hard drive activity LED on the chassis front panel. The LED is on when the hard drive is reading or writing data.

The front panel design may differ by chassis. A front panel module mainly consists of power switch, reset switch, power LED, hard drive activity LED, speaker and etc. When connecting your chassis front panel module to this header, make sure the wire assignments and the pin assignments are matched correctly.

Power LED and Speaker Header  
(7-pin SPK\_PLED1)  
(see p.7, No. 14)

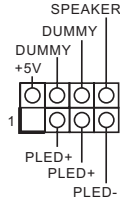

Please connect the chassis power LED and the chassis speaker to this header.

Serial ATA3 Connectors  
(SATA3\_1:  
see p.7, No. 12) (Upper)  
(SATA3\_2:  
see p.7, No. 11) (Lower)  
(SATA3\_3:  
see p.7, No. 9) (Upper)  
(SATA3\_4:  
see p.7, No. 10) (Lower)

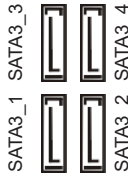

These four SATA3 connectors support SATA data cables for internal storage devices with up to 6.0 Gb/s data transfer rate.  
\* M2\_2 and SATA3\_3 share lanes. If either one of them is in use, the other one will be disabled.

USB 2.0 Headers  
(9-pin USB\_3\_4)  
(see p.7, No. 20)  
(9-pin USB\_5\_6)  
(see p.7, No. 19)

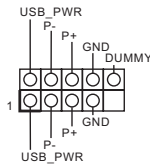

There are two headers on this motherboard. Each USB 2.0 header can support two ports.

USB 3.2 Gen1 Header  
(19-pin USB3\_56)  
(see p.7 or 8, No. 8)

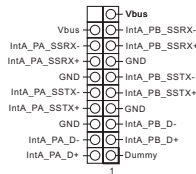

There is one header on this motherboard. Each USB 3.2 Gen1 header can support two ports.

Front Panel Audio Header  
(9-pin HD\_AUDIO1)  
(see p.7, No. 25)

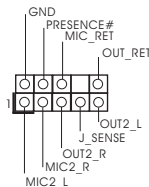

This header is for connecting audio devices to the front audio panel.



1. High Definition Audio supports Jack Sensing, but the panel wire on the chassis must support HDA to function correctly. Please follow the instructions in our manual and chassis manual to install your system.
2. If you use an AC'97 audio panel, please install it to the front panel audio header by the steps below:
  - A. Connect Mic\_IN (MIC) to MIC2\_L.
  - B. Connect Audio\_R (RIN) to OUT2\_R and Audio\_L (LIN) to OUT2\_L.
  - C. Connect Ground (GND) to Ground (GND).
  - D. MIC\_RET and OUT\_RET are for the HD audio panel only. You don't need to connect them for the AC'97 audio panel.
  - E. To activate the front mic, go to the "FrontMic" Tab in the Realtek Control panel and adjust "Recording Volume".

**Chassis/Water Pump Fan Connectors**

- (4-pin CHA\_FAN1/WP)  
(see p.7, No. 26)
- (4-pin CHA\_FAN2/WP)  
(see p.7, No. 16)
- (4-pin CHA\_FAN3/WP)  
(see p.7, No. 17)

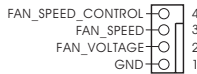

This motherboard provides three 4-Pin water cooling chassis fan connectors. If you plan to connect a 3-Pin chassis water cooler fan, please connect it to Pin 1-3.

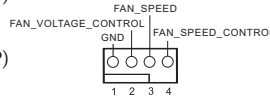

**CPU Fan Connector**  
(4-pin CPU\_FAN1)  
(see p.7, No. 3)

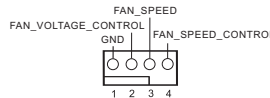

This motherboard provides a 4-Pin CPU fan (Quiet Fan) connector. If you plan to connect a 3-Pin CPU fan, please connect it to Pin 1-3.

**CPU/Water Pump Fan Connector**  
(4-pin CPU\_FAN2/WP)  
(see p.7, No. 2)

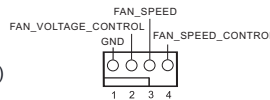

This motherboard provides a 4-Pin water cooling CPU fan connector. If you plan to connect a 3-Pin CPU water cooler fan, please connect it to Pin 1-3.

ATX Power Connector  
(24-pin ATXPWR1)  
(see p.7, No. 7)

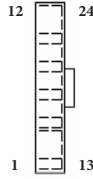

This motherboard provides a 24-pin ATX power connector. To use a 20-pin ATX power supply, please plug it along Pin 1 and Pin 13.

ATX 12V Power Connector  
(8-pin ATX12V1)  
(see p.7, No. 1)

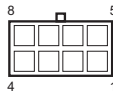

This motherboard provides a 8-pin ATX 12V power connector. To use a 4-pin ATX power supply, please plug it along Pin 1 and Pin 5.

Serial Port Header  
(9-pin COM1)  
(see p.7, No. 21)

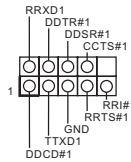

This COM1 header supports a serial port module.

Chassis Intrusion Header  
(2-pin CI1)  
(see p.7, No. 15)



This motherboard supports CASE OPEN detection feature that detects if the chassis cover has been removed. This feature requires a chassis with chassis intrusion detection design.

TPM Header  
(17-pin TPMS1)  
(see p.7, No. 22)

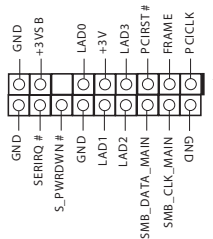

This connector supports Trusted Platform Module (TPM) system, which can securely store keys, digital certificates, passwords, and data. A TPM system also helps enhance network security, protects digital identities, and ensures platform integrity.

AMD FAN LED Header  
(4-pin AMD\_FAN\_  
LED1)  
(see p.7, No. 6)



AMD FAN LED Header is used to connect RGB LED extension cable that comes with AMD heatsink. The cable connection allows users to choose from various LED lighting effects.

**Caution: Never install the FAN LED cable in the wrong orientation; otherwise, the cable may be damaged.**

RGB LED Header  
(4-pin RGB\_LED1)  
(see p.7, No. 23)



This header is used to connect RGB LED extension cable which allows users to choose from various LED lighting effects.

**Caution: Never install the RGB LED cable in the wrong orientation; otherwise, the cable may be damaged.**

\*Please refer to page 51 for further instructions on this header.

Addressable LED Header  
(3-pin ADDR\_LED1)  
(see p.7, No. 24)

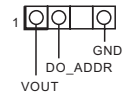

This header is used to connect Addressable LED extension cable which allows users to choose from various LED lighting effects.

**Caution: Never install the Addressable LED cable in the wrong orientation; otherwise, the cable may be damaged.**

\*Please refer to page 52 for further instructions on this header.

## 2.7 CrossFireX™ and Quad CrossFireX™ Operation Guide

This motherboard supports CrossFireX™ and Quad CrossFireX™ that allows you to install up to two identical PCI Express x16 graphics cards.



1. You should only use identical CrossFireX™-ready graphics cards that are AMD certified.
2. Make sure that your graphics card driver supports AMD CrossFireX™ technology. Download the drivers from the AMD's website: [www.amd.com](http://www.amd.com)
3. Make sure that your power supply unit (PSU) can provide at least the minimum power your system requires. It is recommended to use a AMD certified PSU. Please refer to the AMD's website for details.
4. If you pair a 12-pipe CrossFireX™ Edition card with a 16-pipe card, both cards will operate as 12-pipe cards while in CrossFireX™ mode.
5. Different CrossFireX™ cards may require different methods to enable CrossFireX™. Please refer to AMD graphics card manuals for detailed installation guide.

### 2.7.1 Installing Two CrossFireX™-Ready Graphics Cards

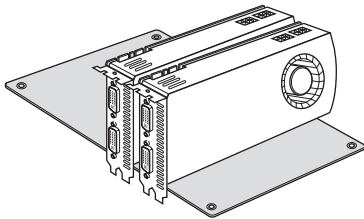

#### Step 1

Insert one graphics card into PCIE2 slot and the other graphics card to PCIE3 slot. Make sure that the cards are properly seated on the slots.



CrossFire Bridge

#### Step 2

Connect two graphics cards by installing a CrossFire Bridge on the CrossFire Bridge Interconnects on the top of the graphics cards. (The CrossFire Bridge is provided with the graphics card you purchase, not bundled with this motherboard. Please refer to your graphics card vendor for details.)

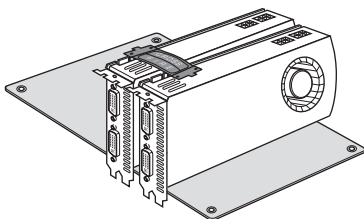

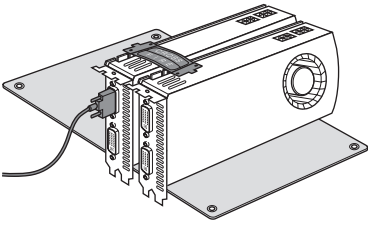
**Step 3**

Connect a VGA/DVI/DP/HDMI cable from the monitor to the corresponding port on the graphics card installed to the PCIE2 slot.

## 2.7.2 Driver Installation and Setup

### Step 1

Power on your computer and boot into OS.

### Step 2

Remove the AMD drivers if you have any VGA drivers installed in your system.



*The Catalyst Uninstaller is an optional download. We recommend using this utility to uninstall any previously installed Catalyst drivers prior to installation. Please check AMD's website for AMD driver updates.*

### Step 3

Install the required drivers and CATALYST Control Center then restart your computer. Please check AMD's website for details.



AMD Catalyst Control Center

### Step 4

Double-click the **AMD Catalyst Control Center** icon in the Windows<sup>®</sup> system tray.

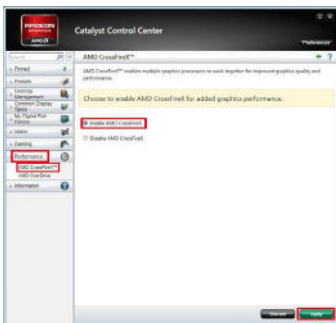

### Step 5

In the left pane, click **Performance** and then **AMD CrossFireX™**. Then select **Enable AMD CrossFireX** and click **Apply**. Select the GPU number according to your graphics card and click **Apply**.



## 2.8 M.2\_SSD (NGFF) Module Installation Guide (M2\_1)

The M.2, also known as the Next Generation Form Factor (NGFF), is a small size and versatile card edge connector that aims to replace mPCIe and mSATA. The Ultra M.2 Socket (M2\_1) supports M Key type 2242/2260/2280 M.2 PCI Express module up to Gen3 x4 (32 Gb/s) (with Matisse, Picasso, Summit Ridge, Raven Ridge and Pinnacle Ridge) or Gen3 x2 (16 Gb/s) (with Athlon series APU).

### Installing the M.2\_SSD (NGFF) Module

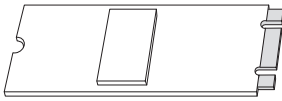

#### Step 1

Prepare a M.2\_SSD (NGFF) module and the screw.

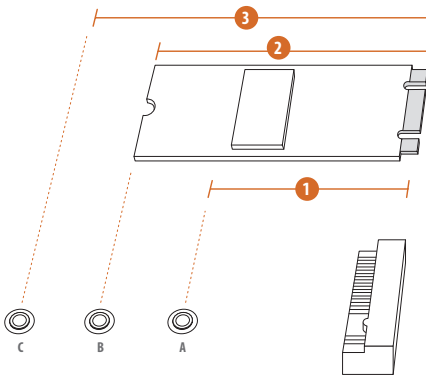

#### Step 2

Depending on the PCB type and length of your M.2\_SSD (NGFF) module, find the corresponding nut location to be used.

No.	1	2	3
Nut Location	A	B	C
PCB Length	4.2cm	6cm	8cm
Module Type	Type 2242	Type 2260	Type 2280

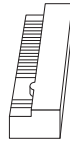

### Step 3

Move the standoff based on the module type and length. The standoff is placed at the nut location C by default. Skip Step 3 and 4 and go straight to Step 5 if you are going to use the default nut. Otherwise, release the standoff by hand.

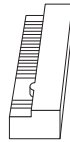

### Step 4

Peel off the yellow protective film on the nut to be used. Hand tighten the standoff into the desired nut location on the motherboard.

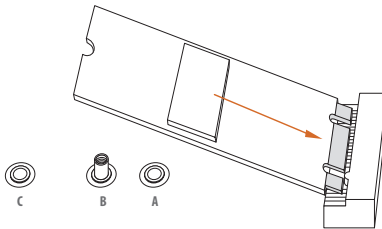

### Step 5

Gently insert the M.2 (NGFF) SSD module into the M.2 slot. Please be aware that the M.2 (NGFF) SSD module only fits in one orientation.

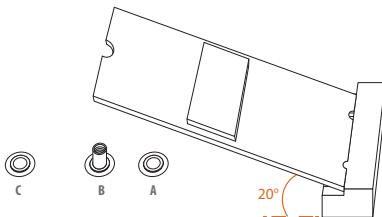

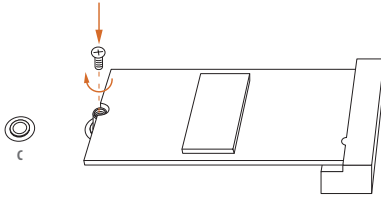
**Step 6**

Tighten the screw with a screwdriver to secure the module into place. Please do not overtighten the screw as this might damage the module.

## M.2\_SSD (NGFF) Module Support List

Vendor	Interface	P/N
Intel	PCIe	INTEL 6000P-SSDPEKKF256G7 (nvme)
Intel	PCIe	INTEL 6000P-SSDPEKKF512G7 (nvme)
Intel	PCIe	INTEL 600P-SSDPEKKW256G7-256GB (nvme)
Kingston	PCIe	Kingston SHPM2280P2 / 240G (Gen2 x4)
SanDisk	PCIe	SanDisk-SD6PP4M-128G(Gen2 x2)
Samsung	PCIe	Samsung XP941-MZHPU512HCGL(Gen2x4)

For the latest updates of M.2\_SSD (NFGG) module support list, please visit our website for details: <http://www.asrock.com>

## 2.9 M.2\_SSD (NGFF) Module Installation Guide (M2\_2)

The M.2, also known as the Next Generation Form Factor (NGFF), is a small size and versatile card edge connector that aims to replace mPCIe and mSATA. The M.2 Socket (M2\_2) supports M Key type 2230/2242/2260/2280 M.2 SATA3 6.0 Gb/s module.

\* M2\_2 and SATA3\_3 share lanes. If either one of them is in use, the other one will be disabled.

### Installing the M.2\_SSD (NGFF) Module

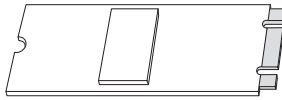

#### Step 1

Prepare a M.2\_SSD (NGFF) module and the screw.

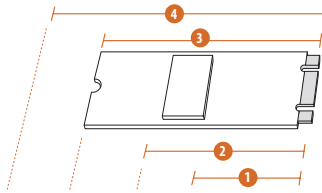

#### Step 2

Depending on the PCB type and length of your M.2\_SSD (NGFF) module, find the corresponding nut location to be used.

No.	1	2	3	4
Nut Location	A	B	C	D
PCB Length	3cm	4.2cm	6cm	8cm
Module Type	Type2230	Type 2242	Type2260	Type 2280

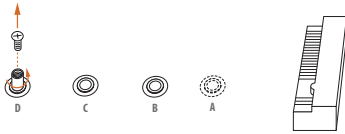
**Step 3**

Move the standoff based on the module type and length. The standoff is placed at the nut location D by default. Skip Step 3 and 4 and go straight to Step 5 if you are going to use the default nut. Otherwise, release the standoff by hand.

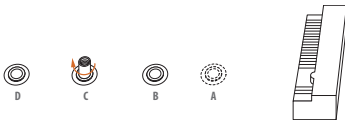
**Step 4**

Peel off the yellow protective film on the nut to be used. Hand tighten the standoff into the desired nut location on the motherboard.

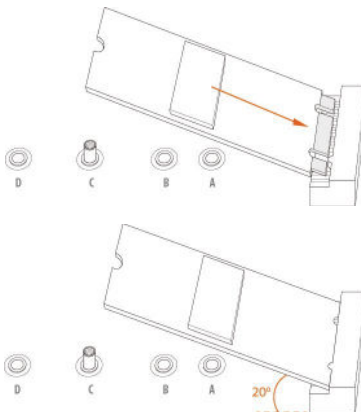
**Step 5**

Gently insert the M.2 (NGFF) SSD module into the M.2 slot. Please be aware that the M.2 (NGFF) SSD module only fits in one orientation.

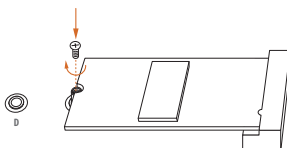
**Step 6**

Tighten the screw with a screwdriver to secure the module into place. Please do not overtighten the screw as this might damage the module.

## M.2\_SSD (NGFF) Module Support List

Vendor	Interface	P/N
ADATA	SATA	ADATA - AXNS381E-128GM-B
Crucial	SATA	Crucial-CT240M500SSD4-240GB
EZLINK	SATA	EZLINK P51B-80-120GB
Intel	SATA	INTEL 540S-SSDSCKKW240H6-240GB
Kingston	SATA	Kingston-RBU-SNS8400S3 / 180GD
Kingston	SATA	Kingston SM2280S3G2/120G - Win8.1
LITEON	SATA	LITEON LJH-256V2G-256GB (2260)
PLEXTOR	SATA	PLEXTOR PX-128M7VG-128GB
PLEXTOR	SATA	PLEXTOR PX-128M6G-2260-128GB
SanDisk	SATA	SanDisk-SD6SN1M-128G
SanDisk	SATA	SanDisk X400-SD8SN8U-128G
SanDisk	SATA	Sandisk Z400s-SD8SNAT-128G-1122
Transcend	SATA	Transcend TS256GMTS800-256GB
Transcend	SATA	Transcend TS64GMTS400-64GB
V-Color	SATA	V-Color 120G
V-Color	SATA	V-Color 240G
WD	SATA	WD BLUE WDS100T1B0B-00A540
WD	SATA	WD GREEN WDS240G1G0B-00RC30

For the latest updates of M.2\_SSD (NFGG) module support list, please visit our website for details: <http://www.asrock.com>

## Chapter 3 Software and Utilities Operation

### 3.1 Installing Drivers

The Support CD that comes with the motherboard contains necessary drivers and useful utilities that enhance the motherboard's features.

#### Running The Support CD

To begin using the support CD, insert the CD into your CD-ROM drive. The CD automatically displays the Main Menu if "AUTORUN" is enabled in your computer. If the Main Menu does not appear automatically, locate and double click on the file "ASRSETUP.EXE" in the Support CD to display the menu.

#### Drivers Menu

The drivers compatible to your system will be auto-detected and listed on the support CD driver page. Please click **Install All** or follow the order from top to bottom to install those required drivers. Therefore, the drivers you install can work properly.

#### Utilities Menu

The Utilities Menu shows the application software that the motherboard supports. Click on a specific item then follow the installation wizard to install it.

## 3.2 A-Tuning

A-Tuning is ASRock's multi purpose software suite with a new interface, more new features and improved utilities.

### 3.2.1 Installing A-Tuning

A-Tuning can be downloaded from ASRock Live Update & APP Shop. After the installation, you will find the icon "A-Tuning" on your desktop. Double-click the "A-Tuning"  icon, A-Tuning main menu will pop up.

### 3.2.2 Using A-Tuning

There are five sections in A-Tuning main menu: Operation Mode, OC Tweaker, System Info, FAN-Tastic Tuning and Settings.

#### Operation Mode

Choose an operation mode for your computer.

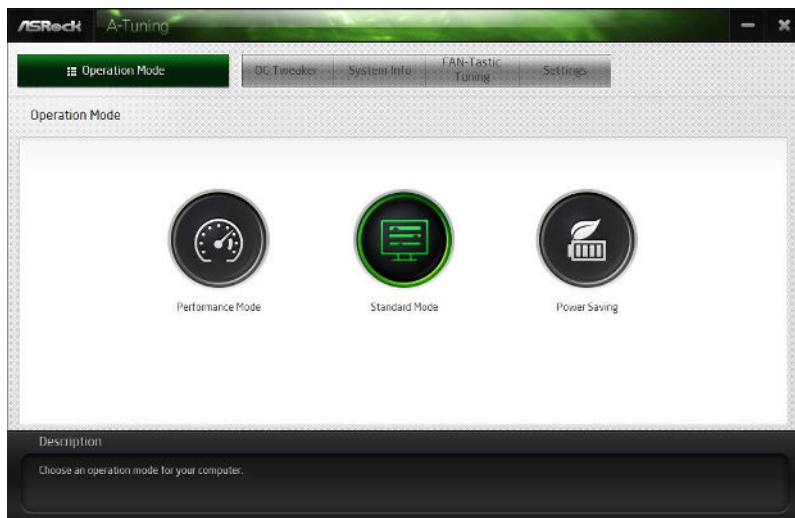



## OC Tweaker

Configurations for overclocking the system.

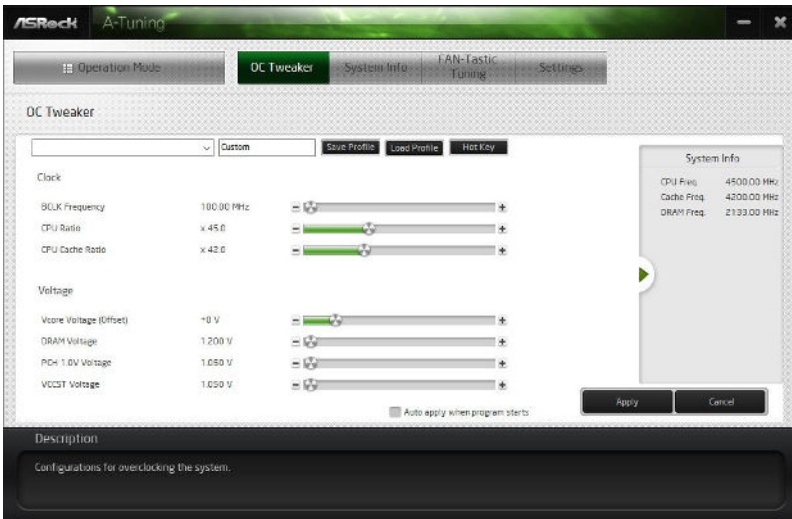

## System Info

View information about the system.

\*The System Browser tab may not appear for certain models.

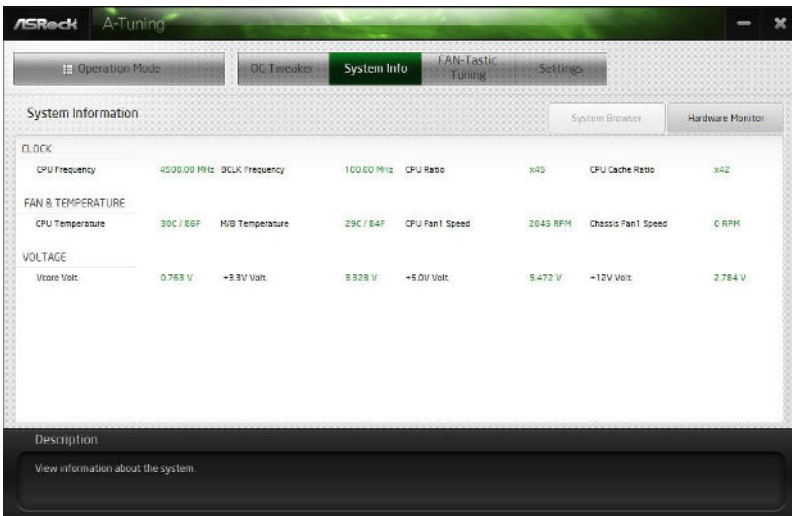

## FAN-Tastic Tuning

Configure up to five different fan speeds using the graph. The fans will automatically shift to the next speed level when the assigned temperature is met.

The screenshot shows the 'FAN-Tastic Tuning' window in ASRock A-Tuning. The window has a title bar with 'ASRock A-Tuning' and standard window controls. Below the title bar are tabs for 'Operation Mode', 'OC Tweaker', 'System Info', 'FAN-Tastic Tuning', and 'Settings'. The 'FAN-Tastic Tuning' tab is selected. The main area contains a 'CPU FANL' dropdown, a 'Start FAN Test' button, and a graph showing fan speed percentage on the y-axis (0 to 100) and temperature in degrees Celsius on the x-axis (0 to 100). A line graph shows a step-like increase in fan speed as temperature rises. To the right of the graph is a table with two columns: 'Fan Power' and 'Fan Speed'. The table lists settings for 100%, 90%, 80%, 70%, 60%, 50%, 40%, 30%, 20%, and 10% fan power, with 'N/A' for fan speed and 'RPM' for the unit. Below the table is a checkbox for 'Auto apply when program starts'. At the bottom right are 'Apply' and 'Cancel' buttons. A 'Description' box at the bottom of the window reads: 'Configure different fan speeds for respective temperatures using the graph. The fans will automatically shift to the next speed level when the assigned temperature is met.'

Fan Power	Fan Speed
100%	N/A RPM
90%	N/A RPM
80%	N/A RPM
70%	N/A RPM
60%	N/A RPM
50%	N/A RPM
40%	N/A RPM
30%	N/A RPM
20%	N/A RPM
10%	N/A RPM

## Settings

Configure ASRock A-Tuning. Click to select "Auto run at Windows Startup" if you want A-Tuning to be launched when you start up the Windows operating system.

The screenshot shows the 'Settings' window in ASRock A-Tuning. The window title is 'ASRock A-Tuning'. The 'Settings' tab is selected. The main area contains a checkbox for 'Auto run at Windows Startup'. At the bottom right, the version number 'Version: 1.0.93' is displayed. A 'Description' box at the bottom of the window reads: 'Configure ASRock A-Tuning.'

### 3.3 ASRock Live Update & APP Shop

The ASRock Live Update & APP Shop is an online store for purchasing and downloading software applications for your ASRock computer. You can quickly and easily install various apps and support utilities. With ASRock Live Update & APP Shop, you can optimize your system and keep your motherboard up to date simply with a few clicks.

Double-click  on your desktop to access ASRock Live Update & APP Shop utility.

*\*You need to be connected to the Internet to download apps from the ASRock Live Update & APP Shop.*

#### 3.3.1 UI Overview

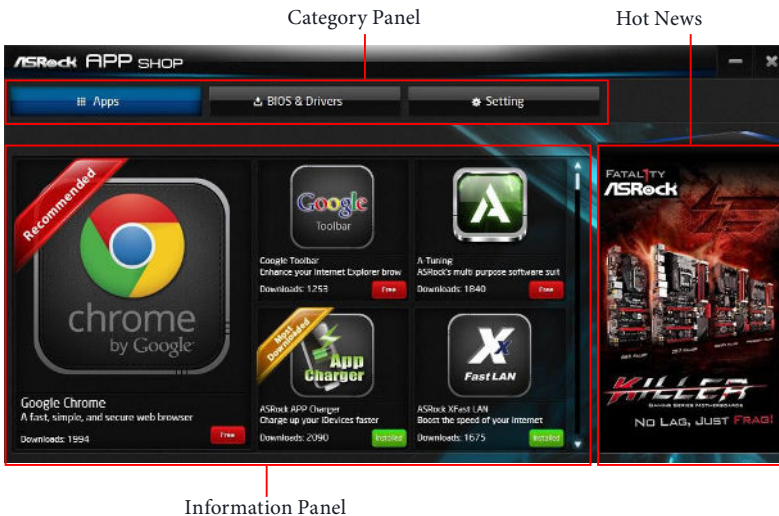

**Category Panel:** The category panel contains several category tabs or buttons that when selected the information panel below displays the relative information.

**Information Panel:** The information panel in the center displays data about the currently selected category and allows users to perform job-related tasks.

**Hot News:** The hot news section displays the various latest news. Click on the image to visit the website of the selected news and know more.

## 3.3.2 Apps

When the "Apps" tab is selected, you will see all the available apps on screen for you to download.

### Installing an App

#### Step 1

Find the app you want to install.



The most recommended app appears on the left side of the screen. The other various apps are shown on the right. Please scroll up and down to see more apps listed.

You can check the price of the app and whether you have already installed it or not.

**Free** - The red icon displays the price or "Free" if the app is free of charge.

**Installed** - The green "Installed" icon means the app is installed on your computer.

#### Step 2

Click on the app icon to see more details about the selected app.

### Step 3

If you want to install the app, click on the red icon  to start downloading.



### Step 4

When installation completes, you can find the green "Installed" icon appears on the upper right corner.

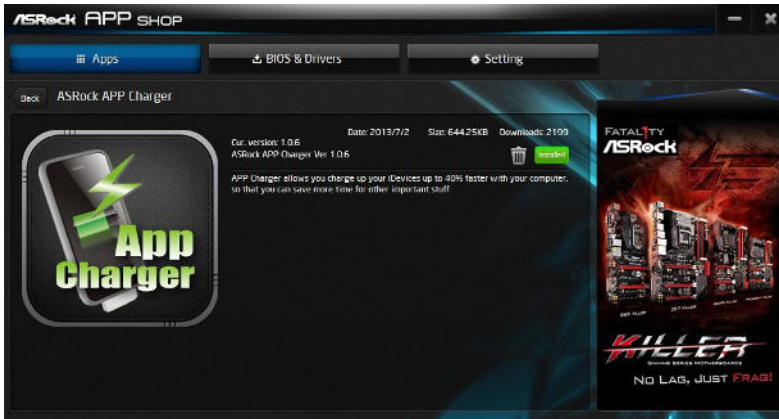

To uninstall it, simply click on the trash can icon .  
\*The trash icon may not appear for certain apps.

## Upgrading an App

You can only upgrade the apps you have already installed. When there is an available new version for your app, you will find the mark of "New Version"  appears below the installed app icon.



### Step 1

Click on the app icon to see more details.

### Step 2

Click on the yellow icon  to start upgrading.

### 3.3.3 BIOS & Drivers

#### Installing BIOS or Drivers

When the "BIOS & Drivers" tab is selected, you will see a list of recommended or critical updates for the BIOS or drivers. Please update them all soon.

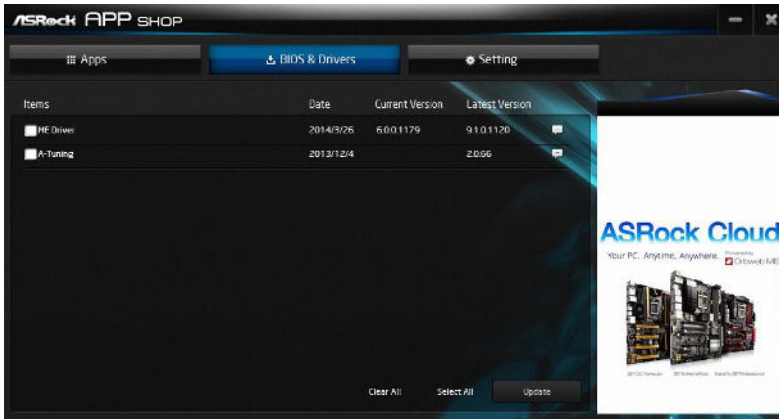

#### Step 1

Please check the item information before update. Click on  to see more details.

#### Step 2

Click to select one or more items you want to update.

#### Step 3

Click Update to start the update process.

### 3.3.4 Setting

In the "Setting" page, you can change the language, select the server location, and determine if you want to automatically run the ASRock Live Update & APP Shop on Windows startup.

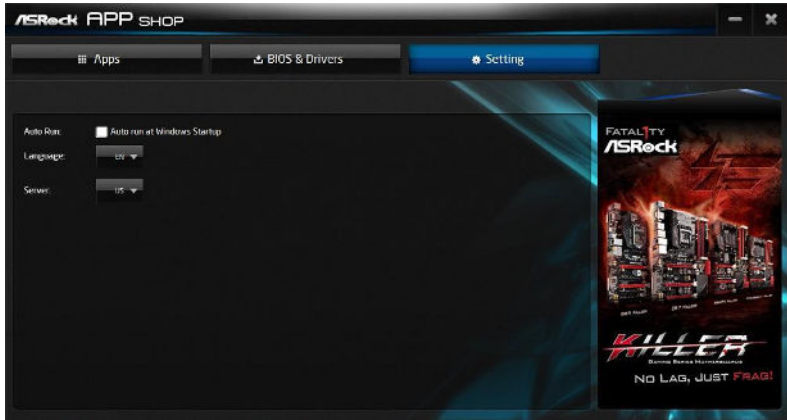



### 3.4 ASRock Polychrome RGB

ASRock Polychrome RGB is a lighting control utility specifically designed for unique individuals with sophisticated tastes to build their own stylish colorful lighting system. Simply by connecting the LED strip, you can customize various lighting schemes and patterns, including Static, Breathing, Strobe, Cycling, Music, Wave and more.

#### Connecting the LED Strip

Connect your RGB LED strips to the **RGB LED Header (RGB\_HEADER1)** on the motherboard.

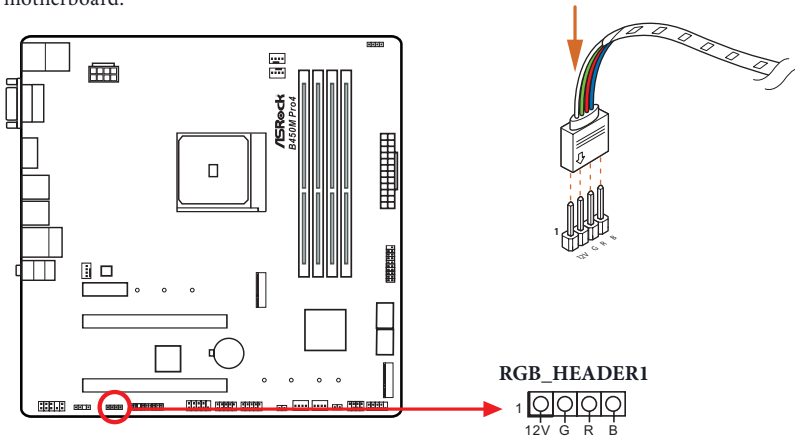

1. Never install the RGB LED cable in the wrong orientation; otherwise, the cable may be damaged.
2. Before installing or removing your RGB LED cable, please power off your system and unplug the power cord from the power supply. Failure to do so may cause damages to motherboard components.



1. Please note that the RGB LED strips do not come with the package.
2. The RGB LED header supports standard 5050 RGB LED strip (12V/G/R/B), with a maximum power rating of 3A (12V) and length within 2 meters.

## Connecting the Addressable RGB LED Strip

Connect your Addressable RGB LED strip to the **Addressable LED Header (ADDR\_LED1)** on the motherboard.

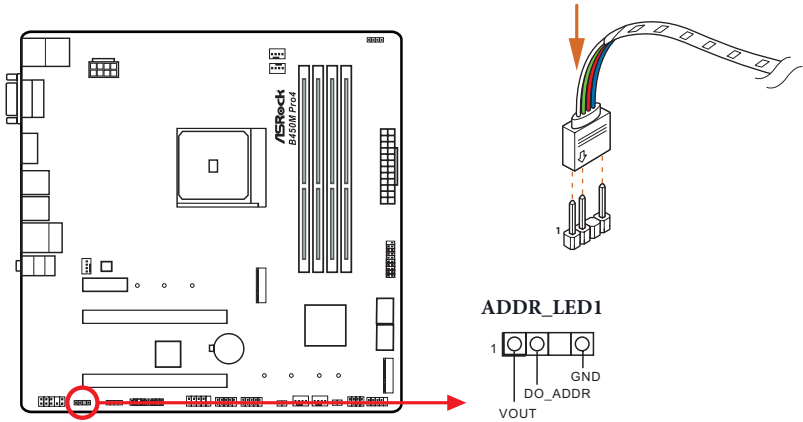

1. Never install the RGB LED cable in the wrong orientation; otherwise, the cable may be damaged.
2. Before installing or removing your RGB LED cable, please power off your system and unplug the power cord from the power supply. Failure to do so may cause damages to motherboard components.



1. Please note that the RGB LED strips do not come with the package.
2. The RGB LED header supports WS2812B addressable RGB LED strip (5V/Data/GND), with a maximum power rating of 3A (5V) and length within 2 meters.

## ASRock Polychrome RGB Utility

Now you can adjust the RGB LED color through the ASRock Polychrome RGB utility. Download this utility from the ASRock Live Update & APP Shop and start coloring your PC style your way!

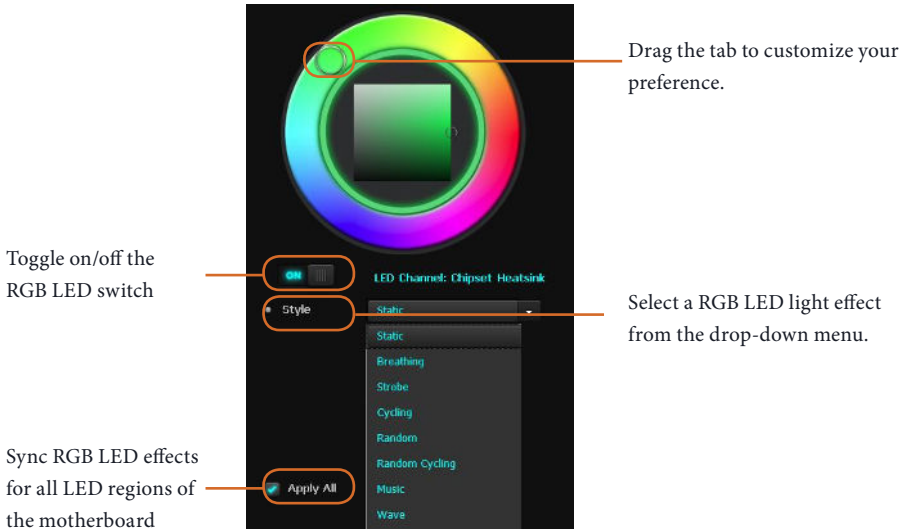

# Chapter 4 UEFI SETUP UTILITY

## 4.1 Introduction

This section explains how to use the UEFI SETUP UTILITY to configure your system. You may run the UEFI SETUP UTILITY by pressing <F2> or <Del> right after you power on the computer, otherwise, the Power-On-Self-Test (POST) will continue with its test routines. If you wish to enter the UEFI SETUP UTILITY after POST, restart the system by pressing <Ctl> + <Alt> + <Delete>, or by pressing the reset button on the system chassis. You may also restart by turning the system off and then back on.



*Because the UEFI software is constantly being updated, the following UEFI setup screens and descriptions are for reference purpose only, and they may not exactly match what you see on your screen.*

### 4.1.1 UEFI Menu Bar

The top of the screen has a menu bar with the following selections:

<b>Main</b>	For setting system time/date information
<b>OC Tweaker</b>	For overclocking configurations
<b>Advanced</b>	For advanced system configurations
<b>Tool</b>	Useful tools
<b>H/W Monitor</b>	Displays current hardware status
<b>Security</b>	For security settings
<b>Boot</b>	For configuring boot settings and boot priority
<b>Exit</b>	Exit the current screen or the UEFI Setup Utility

## 4.1.2 Navigation Keys

Use <←> key or <→> key to choose among the selections on the menu bar, and use <↑> key or <↓> key to move the cursor up or down to select items, then press <Enter> to get into the sub screen. You can also use the mouse to click your required item.

Please check the following table for the descriptions of each navigation key.

Navigation Key(s)	Description
+ / -	To change option for the selected items
<Tab>	Switch to next function
<PGUP>	Go to the previous page
<PGDN>	Go to the next page
<HOME>	Go to the top of the screen
<END>	Go to the bottom of the screen
<F1>	To display the General Help Screen
<F7>	Discard changes and exit the SETUP UTILITY
<F9>	Load optimal default values for all the settings
<F10>	Save changes and exit the SETUP UTILITY
<F12>	Print screen
<ESC>	Jump to the Exit Screen or exit the current screen

## 4.2 Main Screen

When you enter the UEFI SETUP UTILITY, the Main screen will appear and display the system overview.



## 4.3 OC Tweaker Screen

In the OC Tweaker screen, you can set up overclocking features.

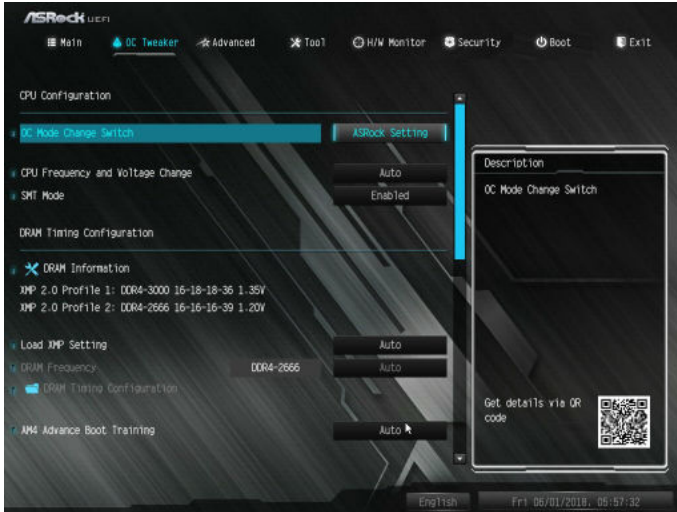

*Because the UEFI software is constantly being updated, the following UEFI setup screens and descriptions are for reference purpose only, and they may not exactly match what you see on your screen.*

### CPU Configuration

#### OC Mode Change Switch

Select a setting for OC Mode.

#### Overclock Mode

Select the overclock mode.

#### CPU Frequency and Voltage Change

If this item is set to [Manual], the multiplier and voltage will be set based on user selection. Final result is depending on the CPU's capability.

#### SMT Mode

This item can be used to disable symmetric multithreading. To re-enable SMT, a power cycle is needed after selecting [Auto].

Warning: S3 is not supported on systems where SMT is disabled.

## DRAM Timing Configuration

### DRAM Frequency

If [Auto] is selected, the motherboard will detect the memory module(s) inserted and assign the appropriate frequency automatically.

### AM4 Advance Boot Training

Set TR4 Advance boot training to [Auto] to increase compatibility.

## Voltage Configuration

### CPU SOC Voltage

Configure the voltage for the CPU SOC.

### Vcore Offset Voltage

Use this to select Vcore Offset Voltage.

### Vcore NB Offset Voltage

Use this to select Vcore NB Offset Voltage.

### DRAM Voltage

Use this to select DRAM Voltage. The default value is [Auto].

### 1.8 Voltage

Use this to select 1.8 Voltage. The default value is [Auto].

### VDDP

Configure the voltage for the VDDP.

### Save User Default

Type a profile name and press enter to save your settings as user default.

### Load User Default

Load previously saved user defaults.

### Save User UEFI Setup Profile to Disk

It helps you to save current UEFI settings as an user profile to disk.

### Load User UEFI Setup Profile from Disk

You can load previous saved profile from the disk.



## 4.4 Advanced Screen

In this section, you may set the configurations for the following items: CPU Configuration, North Bridge Configuration, South Bridge Configuration, Storage Configuration, Super IO Configuration, ACPI Configuration, Trusted Computing, AMD CBS and AMD PBS.

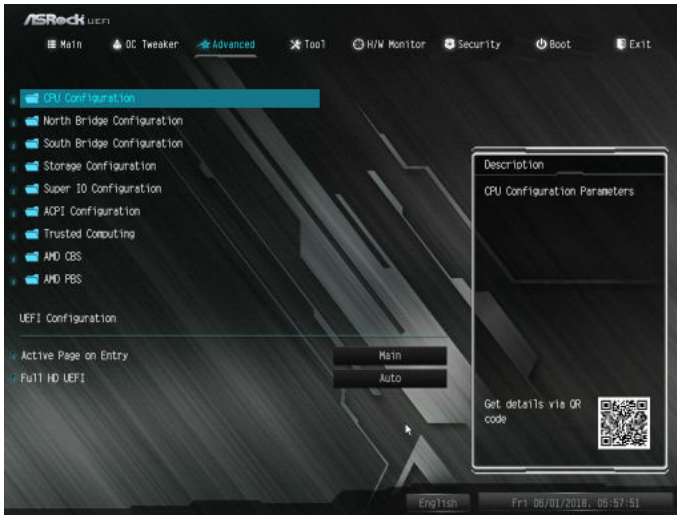

*Setting wrong values in this section may cause the system to malfunction.*

### UEFI Configuration

#### Active Page on Entry

Select the default page when entering the UEFI setup utility.

#### Full HD UEFI

When [Auto] is selected, the resolution will be set to 1920 x 1080 if the monitor supports Full HD resolution. If the monitor does not support Full HD resolution, then the resolution will be set to 1024 x 768. When [Disable] is selected, the resolution will be set to 1024 x 768 directly.

## 4.4.1 CPU Configuration

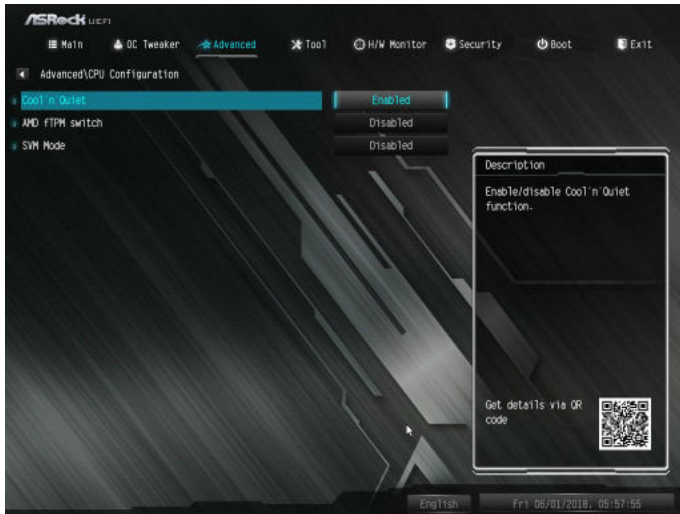

### Cool 'n' Quiet

Use this item to enable or disable AMD's Cool 'n' Quiet™ technology. The default value is [Enabled]. Configuration options: [Enabled] and [Disabled]. If you install Windows® OS and want to enable this function, please set this item to [Enabled]. Please note that enabling this function may reduce CPU voltage and memory frequency, and lead to system stability or compatibility issue with some memory modules or power supplies. Please set this item to [Disable] if above issue occurs.

### AMD fTPM Switch

Use this to enable or disable AMD CPU fTPM.

### SVM Mode

When this option is set to [Enabled], a VMM (Virtual Machine Architecture) can utilize the additional hardware capabilities provided by AMD-V. The default value is [Enabled]. Configuration options: [Enabled] and [Disabled].

## 4.4.2 North Bridge Configuration



### SR-IOV Support

Enable/disable the SR-IOV (Single Root IO Virtualization Support) if the system has SR-IOV capable PCIe devices.

## 4.4.3 South Bridge Configuration

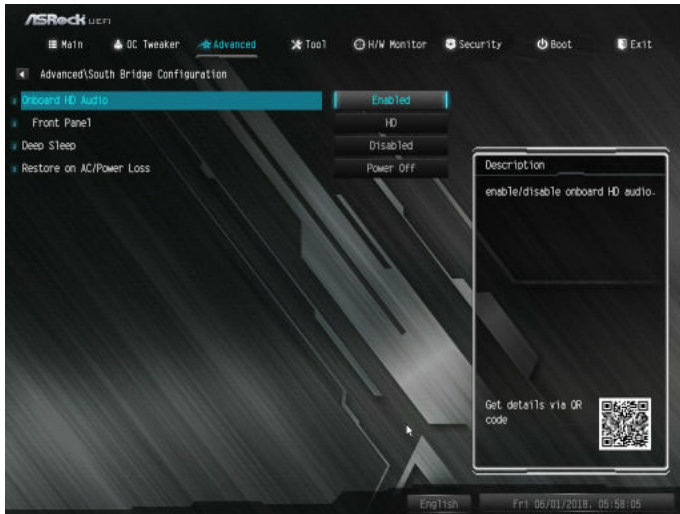

### Onboard HD Audio

Enable/disable onboard HD audio. Set to Auto to enable onboard HD audio and automatically disable it when a sound card is installed.

### Front Panel

Enable/disable front panel HD audio.

### Deep Sleep

Configure deep sleep mode for power saving when the computer is shut down.

### Restore on AC/Power Loss

Select the power state after a power failure. If [Power Off] is selected, the power will remain off when the power recovers. If [Power On] is selected, the system will start to boot up when the power recovers.

## 4.4.4 Storage Configuration



### SATA Controller(s)

Enable/disable the SATA controllers.

### SATA Mode

AHCI: Supports new features that improve performance.

RAID: Combine multiple disk drives into a logical unit.

### SATA Hot Plug

Enable/disable the SATA Hot Plug function.

## 4.4.5 Super IO Configuration

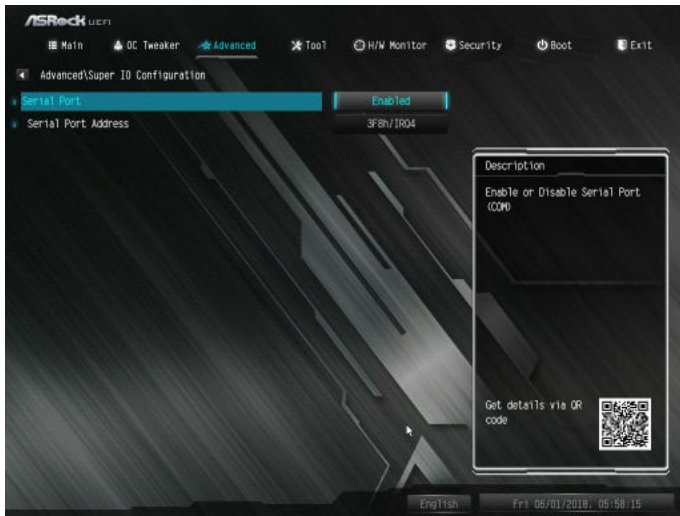

### Serial Port

Enable or disable the Serial port.

### Serial Port Address

Select the address of the Serial port.

## 4.4.6 ACPI Configuration



### Suspend to RAM

It is recommended to select auto for ACPI S3 power saving.

### ACPI HPET Table

Enable the High Precision Event Timer for better performance and to pass WHQL tests.

### PS/2 Keyboard Power On

Allow the system to be waked up by a PS/2 Keyboard.

### PCIE Devices Power On

Allow the system to be waked up by a PCIE device and enable wake on LAN.

### RTC Alarm Power On

Allow the system to be waked up by the real time clock alarm. Set it to By OS to let it be handled by your operating system.

## 4.4.7 Trusted Computing

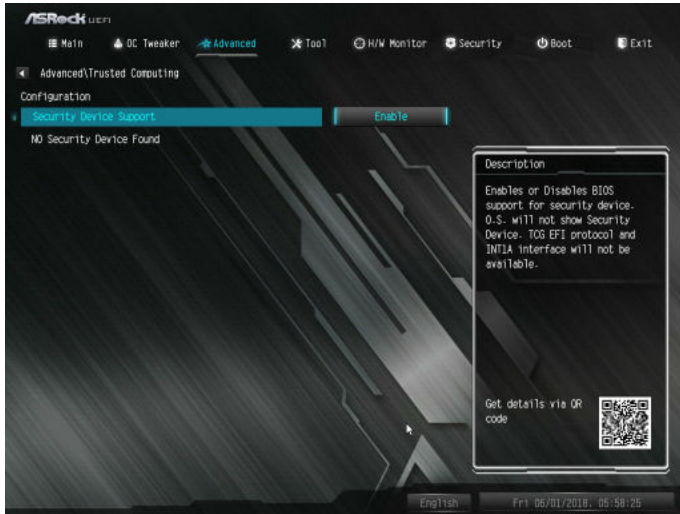

### Security Device Support

Enable to activate Trusted Platform Module (TPM) security for your hard disk drives.



## 4.4.8 AMD CBS



### Zen Common Options

#### RedirectForReturnDis

From a workaround for GCC/C000005 issue for XV Core on CZ A0, setting MSRC001\_1029 Decode Configuration (DE\_CFG) bit 14 [DecfgNoRdrctForReturns] to 1.

#### L2 TLB Associativity

0 - L2 TLB ways [11:8] are fully associative. 1 - =L2 TLB ways [11:8] are 4K-only.

#### Platform first Error Handling

Enable/disable PFEH, cloak individual banks, and mask deferred error interrupts from each bank.

#### Core Performance Boost

Disable CPB.

#### Enable IBS

Enables IBS through MSRC001\_1005[42] and disables SpecLockMap through MSRC001\_1020[54].

#### Global C-state Control

Controls IO based C-state generation and DF C-states.

## Opcache Control

Enables or disables the Opcache.

## OC Mode

OC1 - 16 cores/3.6GHz on 1.3375V

OC2 - 8 cores/3.7GHz on 1.369V

OC3 - 4 cores/3.75GHz on 1.374V\nMax Stress - 16 cores/3.8GHz on 1.400V

## SEV-ES ASID Space Limit

SEV VMs using ASIDs below the SEV-ES ASID Space Limit must enable the SEV-ES feature.

The valid values for this field are from 0x1 (1) - 0x10 (16).

## Core/Thread Enablement

### Downcore control

Sets the number of cores to be used. Once this option has been used to remove any cores, a POWER CYCLE is required in order for future selections to take effect.

### SMTEN

This item can be used to disable symmetric multithreading. To re-enable SMT, a POWER CYCLE is needed after selecting the 'Auto' option.

Warning: S3 is NOT SUPPORTED on systems where SMT is disabled.

## Streaming Stores Control

Enables or disables the streaming stores functionality.

## DF Common Options

### DRAM scrub time

Provide a value that is the number of hours to scrub memory.

### Redirect scrubber control

Control DF::RedirScrubCtrl[EnRedirScrub]

### Disable DF sync flood propagation

Control DF::PIEConfig[DisSyncFloodProp].

### Freeze DF module queues on error

Controls DF::PIEConfig[DisImmSyncFloodOnFatalError]

Disabling this option sets DF::PIEConfig[DisImmSyncFloodOnFatalError].

## GMI encryption control

GMI encryption control

## Control GMI link encryption

xGMI encryption control

## Control xGMI link encryption

## CC6 memory region encryption

Control whether or not the CC6 save/restore memory is encrypted

## Location of private memory regions

Controls whether or not the private memory regions (PSP, SMU and CC6) are at the top of DRAM or distributed. Note that distributed requires memory on all dies. Note that it will always be at the top of DRAM if some dies don't have memory regardless of this option's setting.

## System probe filter

Controls whether or not the probe filter is enabled. Has no effect on parts where the probe filter is fuse disabled.

## Memory interleaving

Controls fabric level memory interleaving (AUTO, none, channel, die, socket). Note that channel, die, and socket has requirements on memory populations and it will be ignored if the memory doesn't support the selected option.

## Memory interleaving size

Controls the memory interleaving size. The valid values are AUTO, 256 bytes, 512 bytes, 1 Kbytes or 2Kbytes. This determines the starting address of the interleave (bit 8, 9, 10 or 11).

## Channel interleaving hash

Controls whether or not the address bits are hashed during channel interleave mode. This field should not be used unless the interleaving is set to channel and the interleaving size is 256 or 512 bytes.

## Memory Clear

When this feature is disabled, BIOS does not implement MemClear after memory training (only if non-ECC DIMMs are used).

## UMC Common Options

### DDR4 Common Options

### DRAM Controller Configuration

DRAM Controller Configuration

### DRAM Power Options

### Cmd2T

Select between 1T and 2T mode on ADDR/CMD

### Gear Down Mode

Configure the Gear Down Mode.

### CAD Bus Configuration

### CAD Bus Timing User Controls

Setup time on CAD bus signals to Auto or Manual

### CAD Bus Drive Strength User Controls

Drive Strength on CAD bus signals to Auto or Manual

### Data Bus Configuration

### Data Bus Configuration User Controls

Specify the mode for drive strength to Auto or Manual

### Common RAS

### Data Poisoning

Enable/disable data poisoning: UMC\_CH::EccCtrl[UcFatalEn] UMC\_CH::EccCtrl[WREccEn]

Should be enabled/disabled together.

### Security

### TSME

Transparent SME: AddrTweakEn = 1; ForceEncrEn = 1; DataEncrEn = 0

### Data Scramble

Data scrambling: DataScrambleEn

## DRAM Memory Mapping

### Chipselect Interleaving

Interleave memory blocks across the DRAM chip selects for node 0.

### BankGroupSwap

Configure the BankGroupSwap.

### BankGroupSwapAlt

Configure BankGroupSwapAlt.

### Address Hash Bank

Configure the bank address hashing.

### Address Hash CS

Configure the CS address hashing.

## NVDIMM

### Memory MBIST

#### MBIST Enable

Configure the Memory MBIST.

#### MBIST SubType Test

Select MBIST Subtest - Single Chipselect, Multi Chipselect, Address Line Test or execute All test

#### MBIST Aggressors

Enable or disable MBIST Aggressor test.

#### MBIST Per Bit Slave Die Reporting

Enable or disable MBIST per bit slave die result report.

## NBIO Common Options

### NB Configuration

### IOMMU

Use this to enable or disable IOMMU. The default value of this feature is [Disabled].

## Determinism Slider

[Auto]

Use default performance determinism settings

## cTDP Control

[Auto]

Use the fused cTDP.

[Manual]

User can set customized cTDP.

## Fan Control

[Auto]

Use the default fan controller settings.

[Manual]

User can set customized fan controller settings.

## PSI

Disable PSI.

## ACS Enable

Enable ACS.

## PCIe ARI Support

Enables Alternative Routing-ID Interpretation

## CLDO\_VDDP Control

[Manual]

If this option is selected, user can set customized CLDO\_VDDP voltage.

## HD Audio Enable

Enable HD Audio.

## FCH Common Options

## SATA Configuration Options

## SATA Controller

Disable or enable OnChip SATA controller

## Sata RAS Support

Disable or enable Sata RAS Support

## Sata Disabled AHCI Prefetch Function

Configure the Sata Disabled AHCI Prefetch function.

## Aggresive SATA Device Sleep Port 0

Configure the Aggresive SATA Device Sleep Port 0.

## Aggresive SATA Device Sleep Port 1

Configure the Aggresive SATA Device Sleep Port 1.

## USB Configuration Options

### XHCI controller enable

Configure the USB3 controller.

## SD (Secure Digital) Options

### SD Configuration Mode

Select SD Mode.

## Ac Power Loss Options

Select Ac Loss Control Method.

## I2C Configuration Options

## Uart Configuration Options

## ESPI Configuration Options

## XGBE Configuration Options

## eMMC Options

## NTB Common Options

## DRAM Memory Mapping

## Chipselect Interleaving

Interleave memory blocks across the DRAM chip selects for node 0.

## BankGroupSwap

Configure the BankGroupSwap.

## BankGroupSwapAlt

Configure the BankGroupSwapAlt.

## Address Hash Bank

Configure the bank address hashing.

## Address Hash CS

Configure the CS address hashing.

## NVDIMM

## Memory MBIST

### MBIST Enable

Configure the Memory MBIST.

### MBIST SubType Test

Select MBIST Subtest - Single Chipselect, Multi Chipselect, Address Line Test or execute all test.

### MBIST Aggressors

Configure the MBIST Aggressor test.

### MBIST Per Bit Slave Die Reporting

Configure the MBIST per bit slave die result report.



## 4.4.9 AMD PBS



The AMD PBS menu accesses AMD specific features.

## 4.5 Tools



### RGB LED

ASRock Polychrome RGB allows you to adjust the RGB LED color to your liking.

### Easy RAID Installer

Easy RAID Installer helps you to copy the RAID driver from the support CD to your USB storage device. After copying the drivers please change the SATA mode to RAID, then you can start installing the operating system in RAID mode.

### Easy Driver Installer

For users that don't have an optical disk drive to install the drivers from our support CD, Easy Driver Installer is a handy tool in the UEFI that installs the LAN driver to your system via an USB storage device, then downloads and installs the other required drivers automatically.

## Instant Flash

Save UEFI files in your USB storage device and run Instant Flash to update your UEFI.

## Internet Flash - DHCP (Auto IP), Auto

ASRock Internet Flash downloads and updates the latest UEFI firmware version from our servers for you. Please setup network configuration before using Internet Flash.

\*For BIOS backup and recovery purpose, it is recommended to plug in your USB pen drive before using this function.

## Network Configuration

Use this to configure internet connection settings for Internet Flash.

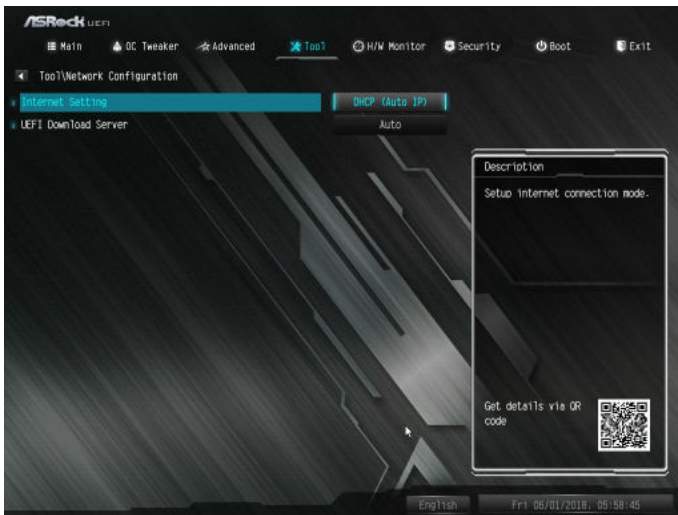

## Internet Setting

Enable or disable sound effects in the setup utility.

## UEFI Download Server

Select a server to download the UEFI firmware.

## 4.6 Hardware Health Event Monitoring Screen

This section allows you to monitor the status of the hardware on your system, including the parameters of the CPU temperature, motherboard temperature, fan speed and voltage.



### Fan Tuning

Measure Fan Min Duty Cycle.

### Fan-Tastic Tuning

Select a fan mode for CPU Fan 1, or choose Customize to set 5 CPU temperatures and assign a respective fan speed for each temperature.

### CPU\_FAN1 Setting

Select a fan mode for CPU Fan 1, or choose Customize to set 5 CPU temperatures and assign a respective fan speed for each temperature.

### CPU\_FAN1 Temp Source

Select a fan temperature source for CPU Fan 1.

### CPU\_FAN2/WP Switch

Select CPU Water Pump mode.

### CPU Fan 2 Control Mode

Select PWM mode or DC mode for CPU fan 2.

### CPU Fan 2 Setting

Select a fan mode for CPU Fan 2, or choose Customize to set 5 CPU temperatures and assign a respective fan speed for each temperature.

### CPU Fan 2 Temp Source

Select a fan temperature source for CPU Fan 2.

### CHA\_FAN1/WP Switch

Select Chassis Fan 1 or Water Pump mode.

### Chassis Fan 1 Control Mode

Select PWM mode or DC mode for Chassis Fan 1.

### Chassis Fan 1 Setting

Select a fan mode for Chassis Fan 1, or choose Customize to set 5 CPU temperatures and assign a respective fan speed for each temperature.

### Chassis Fan 1 Temp Source

Select a fan temperature source for Chassis Fan 1.

### CHA\_FAN2/WP Switch

Select Chassis Fan 2 or Water Pump mode.

### Chassis Fan 2 Control Mode

Select PWM mode or DC mode for Chassis Fan 2.

### Chassis Fan 2 Setting

Select a fan mode for Chassis Fan 2, or choose Customize to set 5 CPU temperatures and assign a respective fan speed for each temperature.

### Chassis Fan 2 Temp Source

Select a fan temperature source for Chassis Fan 2.

### CHA\_FAN3/WP Switch

Select Chassis Fan 3 or Water Pump mode.

### Chassis Fan 3 Control Mode

Select PWM mode or DC mode for Chassis Fan 3.

---

### Chassis Fan 3 Setting

Select a fan mode for Chassis Fan 3, or choose Customize to set 5 CPU temperatures and assign a respective fan speed for each temperature.

### Chassis Fan 3 Temp Source

Select a fan temperature source for Chassis Fan 3.

### Case Open Feature

Enable or disable Case Open Feature to detect whether the chassis cover has been removed.

## 4.7 Security Screen

In this section you may set or change the supervisor/user password for the system. You may also clear the user password.

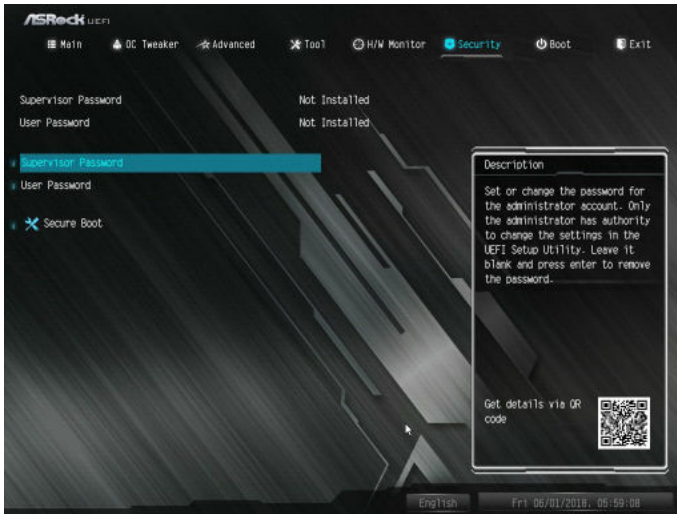

### Supervisor Password

Set or change the password for the administrator account. Only the administrator has authority to change the settings in the UEFI Setup Utility. Leave it blank and press enter to remove the password.

### User Password

Set or change the password for the user account. Users are unable to change the settings in the UEFI Setup Utility. Leave it blank and press enter to remove the password.

### Secure Boot

Enable to support Secure Boot.

## 4.8 Boot Screen

This section displays the available devices on your system for you to configure the boot settings and the boot priority.

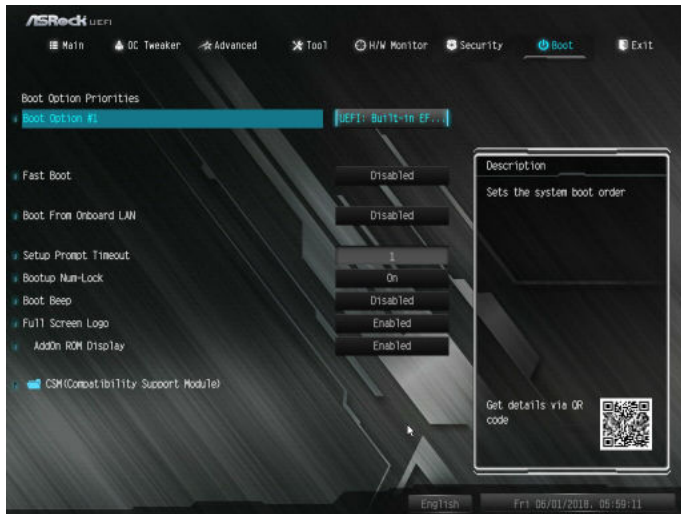

### Fast Boot

Fast Boot minimizes your computer's boot time. In fast mode you may not boot from an USB storage device.

### Boot From Onboard LAN

Allow the system to be waked up by the onboard LAN.

### Setup Prompt Timeout

Configure the number of seconds to wait for the setup hot key.

### Bootup Num-Lock

Select whether Num Lock should be turned on or off when the system boots up.

### Boot Beep

Select whether the Boot Beep should be turned on or off when the system boots up. Please note that a buzzer is needed.

### Full Screen Logo

Enable to display the boot logo or disable to show normal POST messages.



## AddOn ROM Display

Enable AddOn ROM Display to see the AddOn ROM messages or configure the AddOn ROM if you've enabled Full Screen Logo. Disable for faster boot speed.

## CSM (Compatibility Support Module)



## CSM

Enable to launch the Compatibility Support Module. Please do not disable unless you're running a WHCK test.

## Launch PXE OpROM Policy

Select UEFI only to run those that support UEFI option ROM only. Select Legacy only to run those that support legacy option ROM only. Select Do not launch to not execute both legacy and UEFI option ROM.

## Launch Storage OpROM Policy

Select UEFI only to run those that support UEFI option ROM only. Select Legacy only to run those that support legacy option ROM only. Select Do not launch to not execute both legacy and UEFI option ROM.

## 4.9 Exit Screen

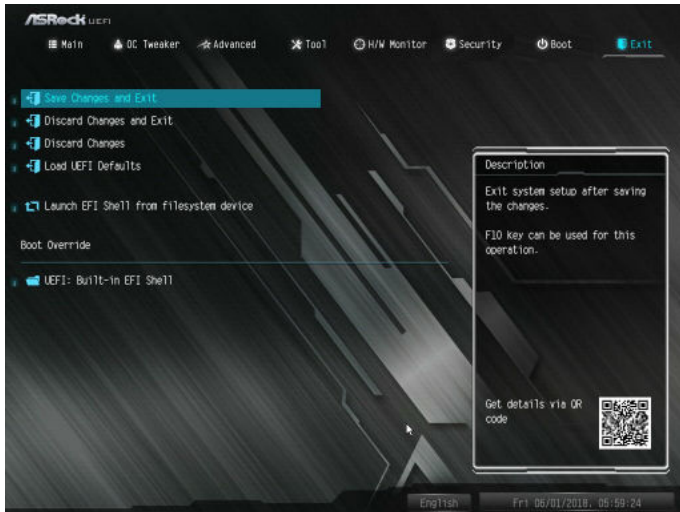

### Save Changes and Exit

When you select this option the following message, “Save configuration changes and exit setup?” will pop out. Select [OK] to save changes and exit the UEFI SETUP UTILITY.

### Discard Changes and Exit

When you select this option the following message, “Discard changes and exit setup?” will pop out. Select [OK] to exit the UEFI SETUP UTILITY without saving any changes.

### Discard Changes

When you select this option the following message, “Discard changes?” will pop out. Select [OK] to discard all changes.

### Load UEFI Defaults

Load UEFI default values for all options. The F9 key can be used for this operation.

### Launch EFI Shell from filesystem device

Copy shellx64.efi to the root directory to launch EFI Shell.

---

## Contact Information

If you need to contact ASRock or want to know more about ASRock, you're welcome to visit ASRock's website at <http://www.asrock.com>; or you may contact your dealer for further information. For technical questions, please submit a support request form at <https://event.asrock.com/tsd.asp>

### **ASRock Incorporation**

2F., No.37, Sec. 2, Jhongyang S. Rd., Beitou District,

Taipei City 112, Taiwan (R.O.C.)

### **ASRock EUROPE B.V.**

Bijsterhuizen 11-11

6546 AR Nijmegen

The Netherlands

Phone: +31-24-345-44-33

Fax: +31-24-345-44-38

### **ASRock America, Inc.**

13848 Magnolia Ave, Chino, CA91710

U.S.A.

Phone: +1-909-590-8308

Fax: +1-909-590-1026

# DECLARATION OF CONFORMITY

Per FCC Part 2 Section 2.1077(a)



**Responsible Party Name:** ASRock Incorporation

**Address:** 13848 Magnolia Ave, Chino, CA91710

**Phone/Fax No:** +1-909-590-8308/+1-909-590-1026

hereby declares that the product

**Product Name :** Motherboard

**Model Number :** B450M Pro4

Conforms to the following specifications:

FCC Part 15, Subpart B, Unintentional Radiators

## Supplementary Information:

This device complies with part 15 of the FCC Rules. Operation is subject to the following two conditions: (1) This device may not cause harmful interference, and (2) this device must accept any interference received, including interference that may cause undesired operation.

Representative Person's Name: James

Signature:

A handwritten signature in black ink, appearing to read 'James', written over a horizontal line.

Date : May 12, 2017

# EU Declaration of Conformity



For the following equipment:

**Motherboard**

(Product Name)

**B450M Pro4 / ASRock**

(Model Designation / Trade Name)

**ASRock Incorporation**

(Manufacturer Name)

**2F., No.37, Sec. 2, Jhongyang S. Rd., Beitou District, Taipei City 112, Taiwan (R.O.C.)**

(Manufacturer Address)

**EMC — Directive 2014/30/EU (from April 20th, 2016)**

EN 55022:2010/AC:2011 Class B

EN 55024:2010/A1:2015

EN 55032:2012+AC:2013 Class B

EN 61000-3-3:2013

EN 61000-3-2:2014

**LVD — Directive 2014/35/EU (from April 20th, 2016)**

EN 60950-1 : 2011+ A2: 2013

EN 60950-1 : 2006/A12: 2011

**RoHS — Directive 2011/65/EU**

**CE marking**

(EU conformity marking)



**ASRock EUROPE B.V.**

(Company Name)

**Bijsterhuizen 1111 6546 AR Nijmegen The Netherlands**

(Company Address)

Person responsible for making this declaration:

(Name, Surname)

**A.V.P**

(Position / Title)

**July 6, 2018**

(Date)

P/N: 15G062108002AK V1.1